



REPLACING THE BACKREST/CHAIR BASE

It is imperative that Human Touch[®] products are repaired in a manner that ensures product safety and regulatory compliance and that is fully consistent with the practices used during the manufacturing process. Therefore, Human Touch requires that all product repairs are performed using only factory-new parts and in accordance with these repair instructions. Failure to adhere to these instructions voids the product warranty and releases Human Touch from all liability for injury or product damage resulting from the repair.

SERVICE LEVEL: 3

Tools Required: Phillips-head screwdriver and pliers. **NOTE:** SAVE ALL SCREWS FOR USE DURING REASSEMBLY.



CAUTION! You will need at least two people to complete this procedure, as the chair is very heavy. Be sure you have enough people to lift and move the chair, to prevent injury.

GET READY

DISCONNECT THE BACKREST FROM THE SEAT CUSHION

1. Plug in the chair and power it on.
2. Use the remote control to fully deploy the calf+foot massager.
3. Reach between the backrest pad and the seat cushion and completely unzip the zipper that connects the backrest to the seat pad. (If the recline works, use the remote to recline the backrest fully for better access to the zipper).
4. If the backrest was reclined, return it halfway to the upright position.
5. Power off the chair and unplug it.

REMOVING THE BACKREST

DISCONNECT THE CABLES (Fig.1)

1. Kneeling at the back of the chair, locate the two side panels.
2. For each side panel, remove the two screws using a Phillips-head screwdriver, then remove the side panel by pulling gently on the cables to release it from the frame. The right side panel remains attached to the air hose.
3. Locate the connectors on the lower left-hand side of the backrest, then disconnect the connectors. **NOTE:** The HT-1650 has seven connectors; the HT-9500 has eight connectors.
4. Locate the three sets of connectors and the air hose on the lower right-hand side of the backrest, then disconnect all three connectors.
5. Using a pliers, squeeze the two hose clamp tabs together to loosen the clamp, slide the clamp up toward the chair, then disconnect the air hose.
6. Locate the junction box in the center of the horizontal backrest frame, then remove the two screws using a Phillips-head screwdriver.
7. Remove the two cables from the **left** side of the junction box, then disconnect the connectors.

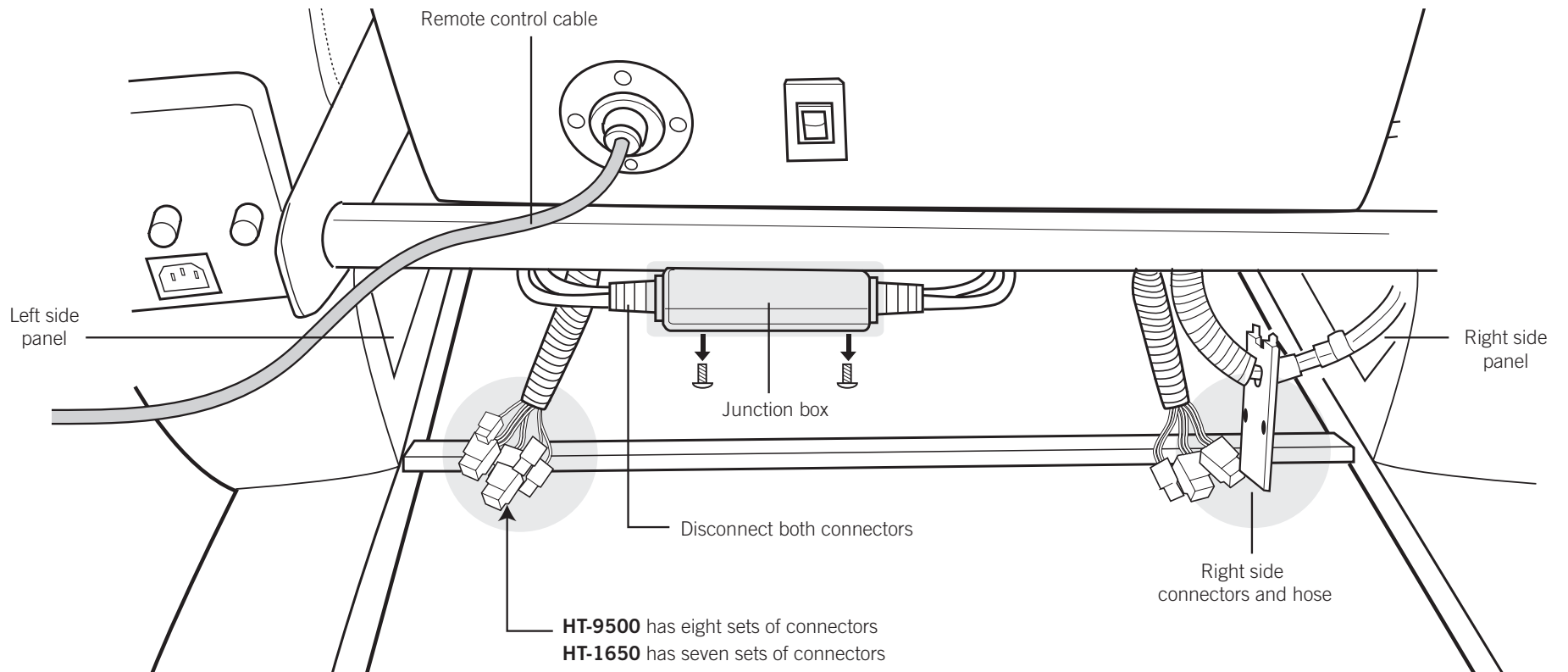

(Fig.1)

DISCONNECT THE REMOTE CONTROL CABLE FROM THE BACKREST

1. Locate the remote control cable at the bottom center of the backrest (Fig.1).
2. Remove the four screws that hold the remote control cable bracket in place, using a Phillips-head screwdriver (Fig.2).
3. Pull the bracket and cable out of the backrest until the connectors are visible, then disconnect the connectors.

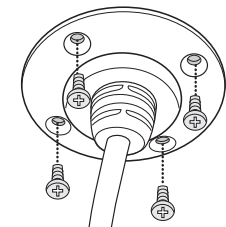

(Fig.2)

REMOVE THE BACKREST FROM THE CHAIR BASE

⚠ This step requires two people

1. With one person standing on each side of the backrest, each person slide the hand closest to the front of the chair down along the front side of the backrest, with the palm of your hand facing the backrest, until you locate the backrest release lever. The lever is located at the bottom of the backrest, in the corner where the backrest meets the chair cushion. (Fig.3)
2. Both people lift up on the backrest release levers simultaneously to release the backrest from the chair base, then lift the backrest up and off the chair base (Fig.4).

(Fig.3)

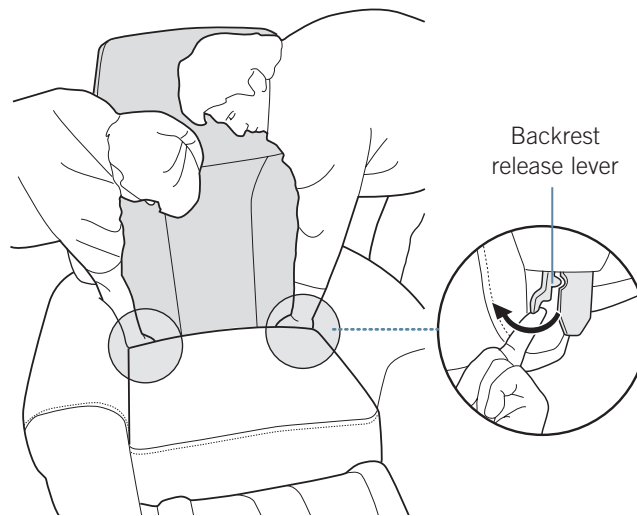

(Fig.4)

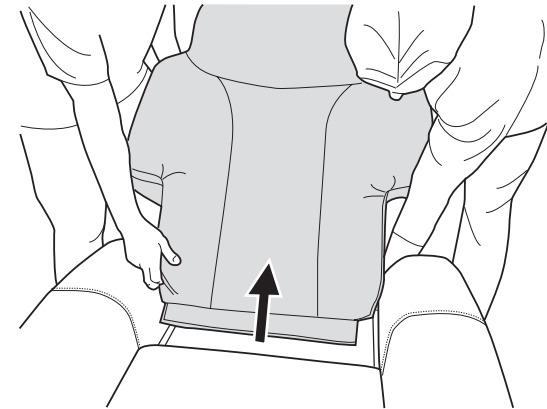

INSTALLING THE BACKREST ONTO THE CHAIR BASE

ATTACH THE BACKREST TO THE CHAIR BASE

⚠ This step requires two people

As the backrest is being installed, make sure the cables from the backrest remain inside of the rear frame of the chair.

1. With one person on each side of the backrest, each person align the tabs on the bottom sides of the backrest with the corresponding slots on the chair base. (The slots are easier to see from the back side of the chair).

2. Slide the tabs into the slots simultaneously until they click into place. (Fig.5)

Important! Both sides must be inserted into the slots at the same time.

3. Gently attempt to move the backrest side-to-side, to ensure that it is securely locked onto the chair base.
When positioned properly, the backrest should be able to move forward and backward, but not side-to-side.

(Fig.5)

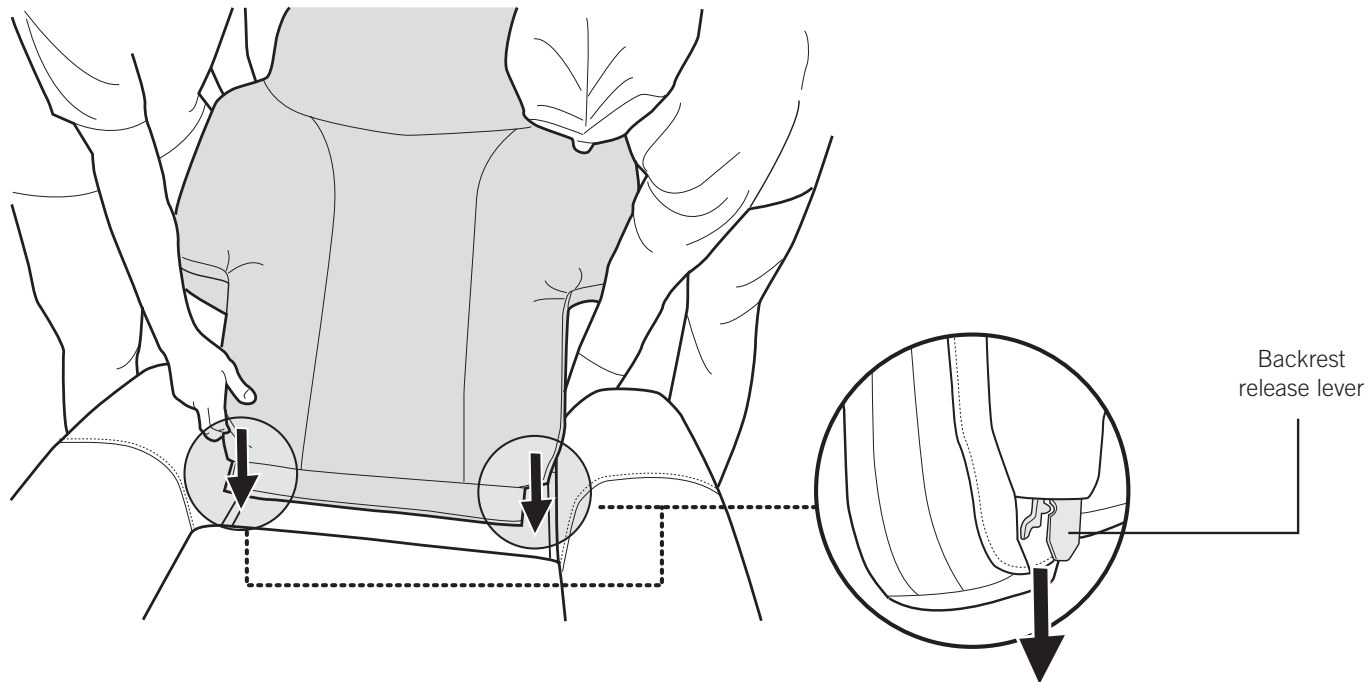

CONNECT THE CABLES

1. Connect the two cables that fit inside the junction box, and then slide the cables into the junction box cable guides to secure them (Fig.6)
2. Replace the junction box cover and secure it, using a Phillips-head screwdriver and the two screws you removed earlier (Fig.6).
3. Connect the three connectors on the lower right-hand side of the chair (Fig.7).
4. Connect the air hose on the right side then, using a pliers, loosen the hose clamp, slide it upward toward the connection, then release it.
5. Push the cables and connectors into the lower right-hand side of the chair. The large set of cables fits into the slot on the end of the side panel.
6. Replace the right-hand panel and secure it, using a Phillips-head screwdriver and the two screws you removed earlier.
7. Connect the connectors on the lower left-hand side of the chair (Fig.8).
8. Push the cables and connectors into the side of the chair. The large set of cables fit into the slot on the end of the side panel.
9. Replace the left-hand panel and secure it, using a Phillips-head screwdriver and the two screws you removed earlier.

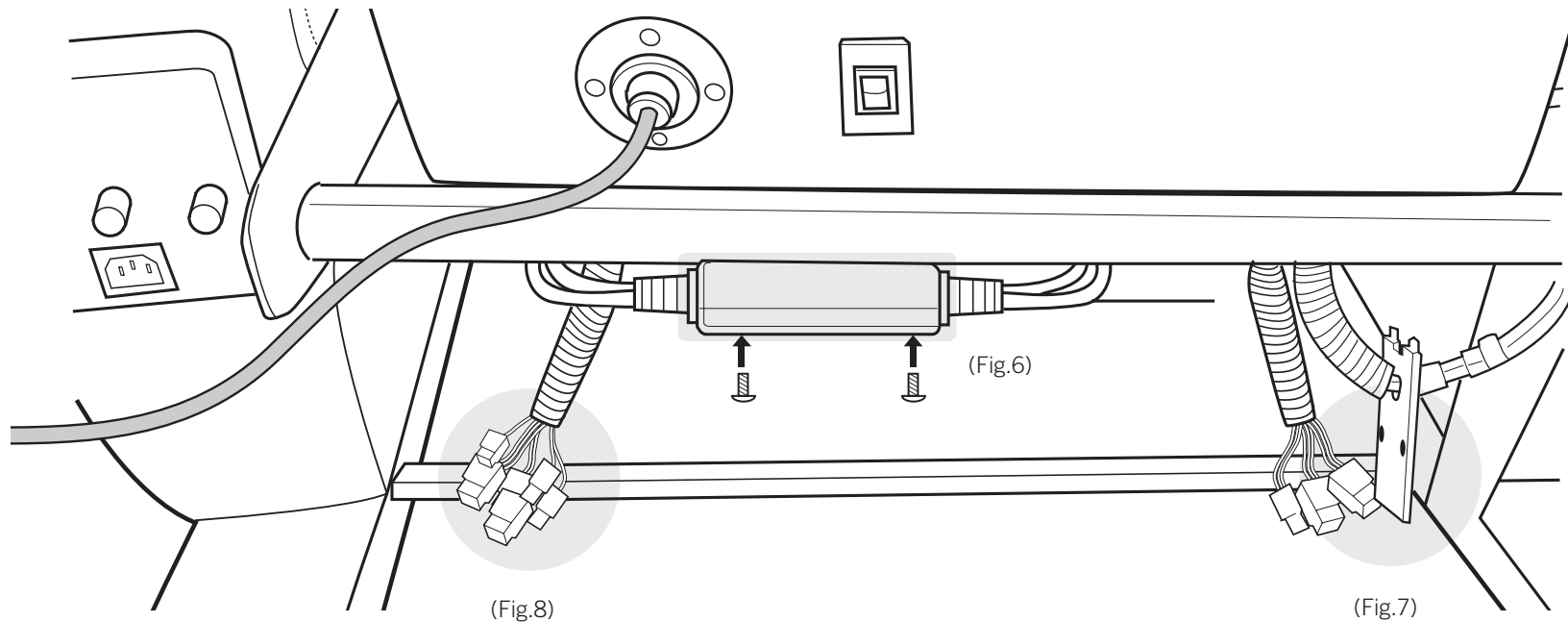

REPLACE THE REMOTE CONTROL CABLE

1. Connect the remote control cable to the corresponding cable in the bottom center of the backrest, then push the cables into the back of the chair.
2. Using a Phillips-head screwdriver and the four screws you removed earlier, secure the remote control bracket to the chair.

TEST THE CHAIR

1. Plug the chair back in and power it on.
2. Verify that the chair functions work properly. The remote control LED display indicates an error if any connections are incomplete (Fig.9).

ZIP THE BACKREST ZIPPER

1. Use the remote control to fully recline the backrest (Fig.10).
2. Attach and close the zippers to secure the backrest to the seat cushion.

