

REPLACING THE FOOT AND CALF MASSAGER ACTUATOR

To ensure that Human Touch® products are repaired in a manner that is fully consistent with the practices used during the manufacturing process, Human Touch requires that all product repairs are performed using only factory-new parts and in accordance with these product repair instructions.

SERVICE LEVEL: 3

Tools Required: Small Phillips-head screwdriver, needle-nosed pliers, two people (to turn the chair on its side)

NOTE: SAVE ALL REMOVED PARTS FOR USE DURING REASSEMBLY

GET READY

1. Power off the chair and unplug it.

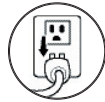

2. Using two people, turn the chair gently on its right-hand side (Fig.1).

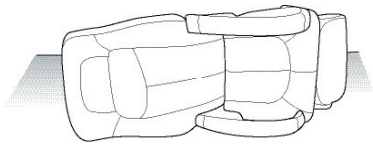

(Fig.1)

REMOVING THE ACTUATOR

1. Locate the connector box on the bottom left side of the chair (Fig.2).
2. Using your fingers, pull the connector box apart, then remove it (Fig.2).
3. Disconnect the connector.

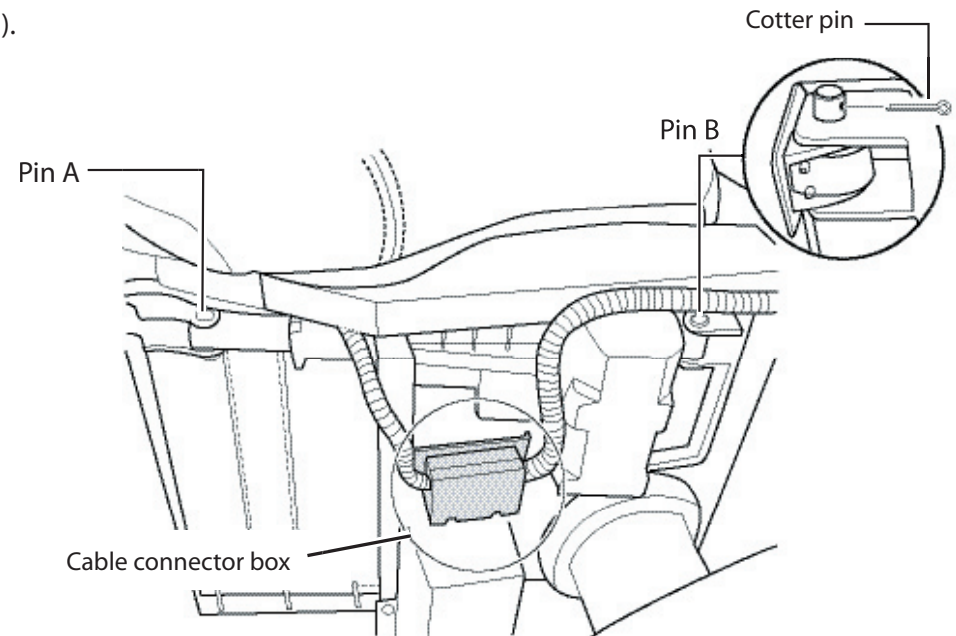

Bottom chair on side

(Fig.2)

4. Locate actuator pin A (Fig. 2), then use a needle-nosed pliers to pop the c-clamp off the top (Fig.3).
5. Use a flat-head screwdriver to pry the pin loose (from the bottom), then remove it (Fig.3).
6. Locate actuator pin B (Fig. 2), then use a needle-nosed pliers to remove the cotter pin from the top of the hinge pin.
7. Use a flat-head screwdriver to pry the hinge pin loose (from the bottom).

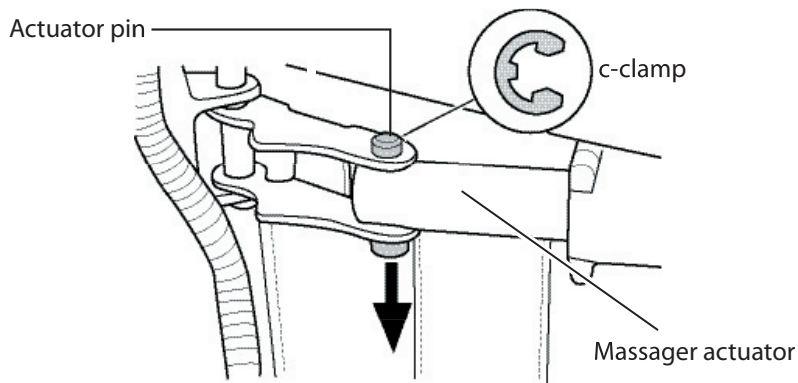

(Fig.3)

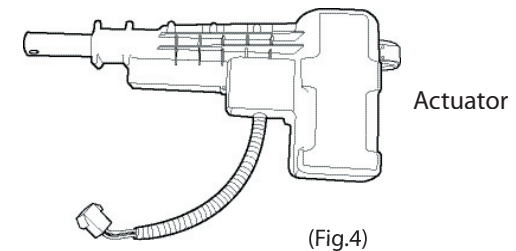

(Fig.4)

INSTALLING THE NEW ACTUATOR

1. Place the actuator into position, aligning the shaft with the mounting bracket near the front of the chair.
2. Insert pin A through the bracket and the shaft, from the bottom up.
3. Replace the c-clamp at the top of the pin, then use a needle-nosed pliers to pinch it closed.
4. Align the mounting point on the back of the actuator with the corresponding bracket.
5. Insert pin B through the bracket and the mounting point, from the bottom up.
6. Replace the cotter pin at the top of the hinge pin, then use a needle-nosed pliers to bend the ends back, to hold the cotter pin in place.
7. Reconnect the connector you disconnected previously.
8. Position the cables inside the connector box, with the cables resting in the cable guides.
9. Using your fingers, snap the two sides of the connector box back together to secure it.
10. Return all cabling to its original location and secure it to the bottom of the chair using new zip ties.