

REPLACING THE BACKREST

To ensure that Human Touch® products are repaired in a manner that is fully consistent with the practices used during the manufacturing process, Human Touch requires that all product repairs are performed using only factory-new parts and in accordance with these product repair instructions.

SERVICE LEVEL: 3

Tools Required: Needle-nosed pliers, vice grip, Phillips-head screwdriver, small hammer

NOTE: This procedure can be completed by one person, although having a second person is helpful when installing the new backrest. **SAVE ALL SCREWS FOR USE DURING REASSEMBLY.**

GET READY

1. Use the remote control to completely recline the backrest.
2. Place a sturdy object, such as a heavy box or ottoman, under the reclined backrest for support (Fig.1). NOTE: This is necessary as, once the recline actuator is removed, the backrest swings freely.
3. Power off the chair and unplug it.

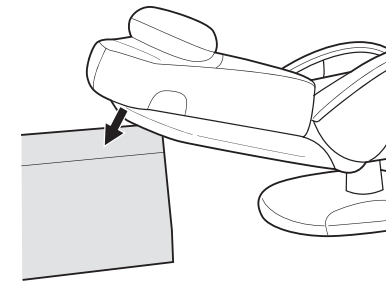

(Fig.1)

REMOVING THE BACKREST

1. Locate the connector box on the bottom left-hand side of the chair, near the foot and calf massager (Fig.2).
2. Using a Phillips-head screwdriver, remove the two screws that secure the connector box cover, remove the cover, then disconnect the two connectors.
3. Locate the connector box on the bottom right-hand side of the chair, near the footrest handle (Fig.3).
4. Using a Phillips-head screwdriver, remove the two screws that secure the connector box cover, remove the cover, then disconnect the two connectors.
5. Remove all zip ties that secure the two backrest connectors to the bottom of the chair.
6. Pull gently outward on one of the side panel covers to remove it (Fig.4).

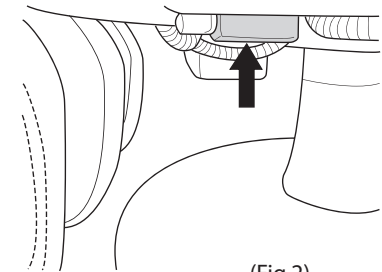

(Fig.2)

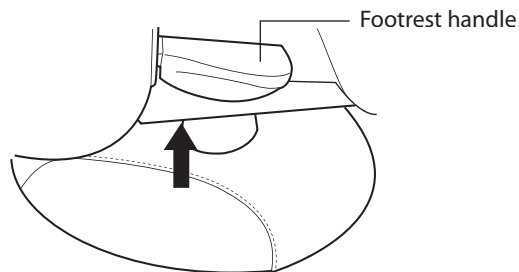

(Fig.3)

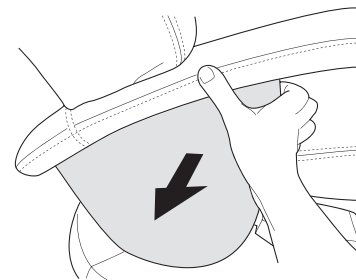

(Fig.4)

7. Using a needle-nosed pliers, remove the cotter pin from the side panel (Fig.5).
8. Using a vice grip, pry the hinge pin loose from the side panel then remove it.
9. Remove the two spacers from between the backrest and the chair base (Fig.6).
10. Repeat steps 6-9 on the other side panel.
11. Press the silver backrest release lever, located on the bottom of the backrest, to release the backrest from the actuator.
12. Detach the upholstered flap at the bottom of the backrest from the hook and loop fasteners on the bottom of the chair base.
13. Pull the backrest up and off the chair base.

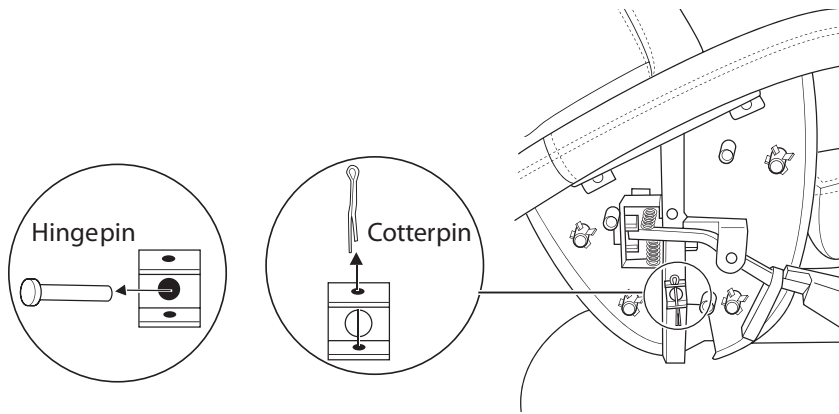

(Fig.5)

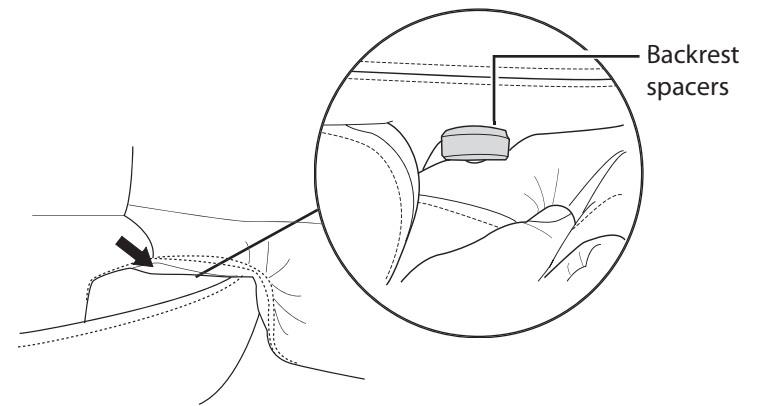

(Fig.6)

INSTALLING THE NEW BACKREST

1. Position the new backrest onto the new chair base, supporting it with the sturdy object you used when removing the backrest.
2. From the outside of one of the side panels, insert the hinge pin through the hole, just until it is visible on the inside of the side panel.
3. Place the two spacers into position on the inside of the side panel, with the smaller spacer between the larger spacer and the side panel, then push the hinge pin through both spacers (Fig.7).
4. Use your fingers to locate the circular bracket in the side of the backrest before attempting to insert the hinge pin into the backrest. You can easily locate the hole by pushing firmly inward on the side of the backrest until you feel the metal bracket beneath the upholstery.
5. Insert the hinge pin as far into the bracket as possible, then use a small hammer to install it completely into the bracket.
6. Insert the cotter pin into the hinge pin, then use a needle-nosed pliers to bend the ends back.

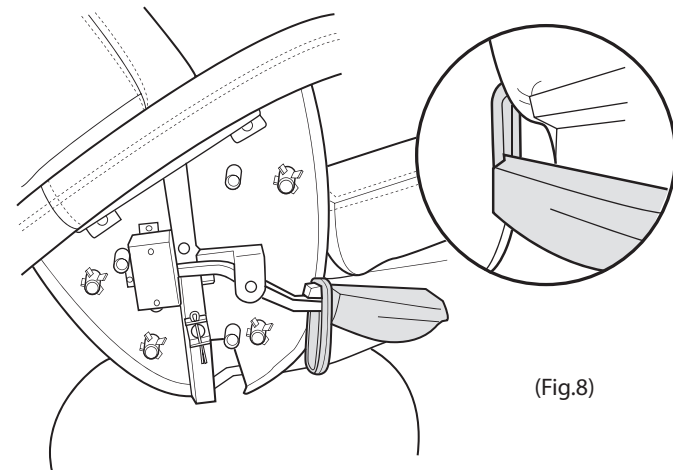
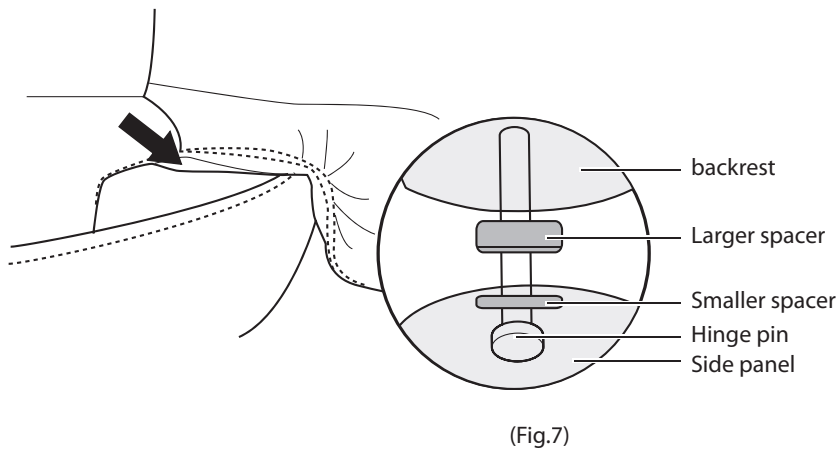

7. Replace the side panel cover, by aligning the plugs on the inside of the cover with the corresponding holes on the chair, then pushing the cover firmly into place (Fig.9).

NOTE: Before installing the right-hand side panel cover, you must position the spacer as shown in Fig. 8.

Once the side panel cover is installed, push the spacer into the side panel cover slot.

8. Repeat steps 2 - 7 on the other side panel.
9. Reconnect the cables at the connector box on the bottom right-hand side of the chair, near the footrest handle (Fig. 3).
10. Using a Phillips-head screwdriver, secure the connector box cover using the two screws you removed earlier.
11. Reconnect the cables at the connector box on the bottom left side of the chair, near the foot and calf massager (Fig.2).
12. Using a Phillips-head screwdriver, secure the connector box cover using the two screws you removed earlier.
13. Replace the zip ties you removed previously, to secure the two backrest connectors to the bottom of the chair.
14. Attach the upholstered flap at the bottom of the backrest to the hook and loop fasteners on the bottom of the chair base.
15. Plug in the chair, power it on, and verify that both the massage and recline functions work.

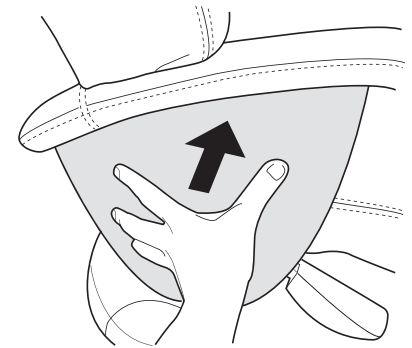

(Fig.9)