

UNPACKING/PACKAGING THE CHAIR FOR SHIPPING

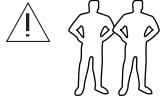

CAUTION! Your massage chair is a precision instrument that can be damaged if dropped. You will need at least two people to complete this procedure, Be sure you have enough people to lift and move the chair, to prevent injury.

SERVICE LEVEL: 2

NOTE: Save all packaging materials - you will need them to package the existing chair properly for shipping back to Human Touch.

List of components for packing (Fig.1):

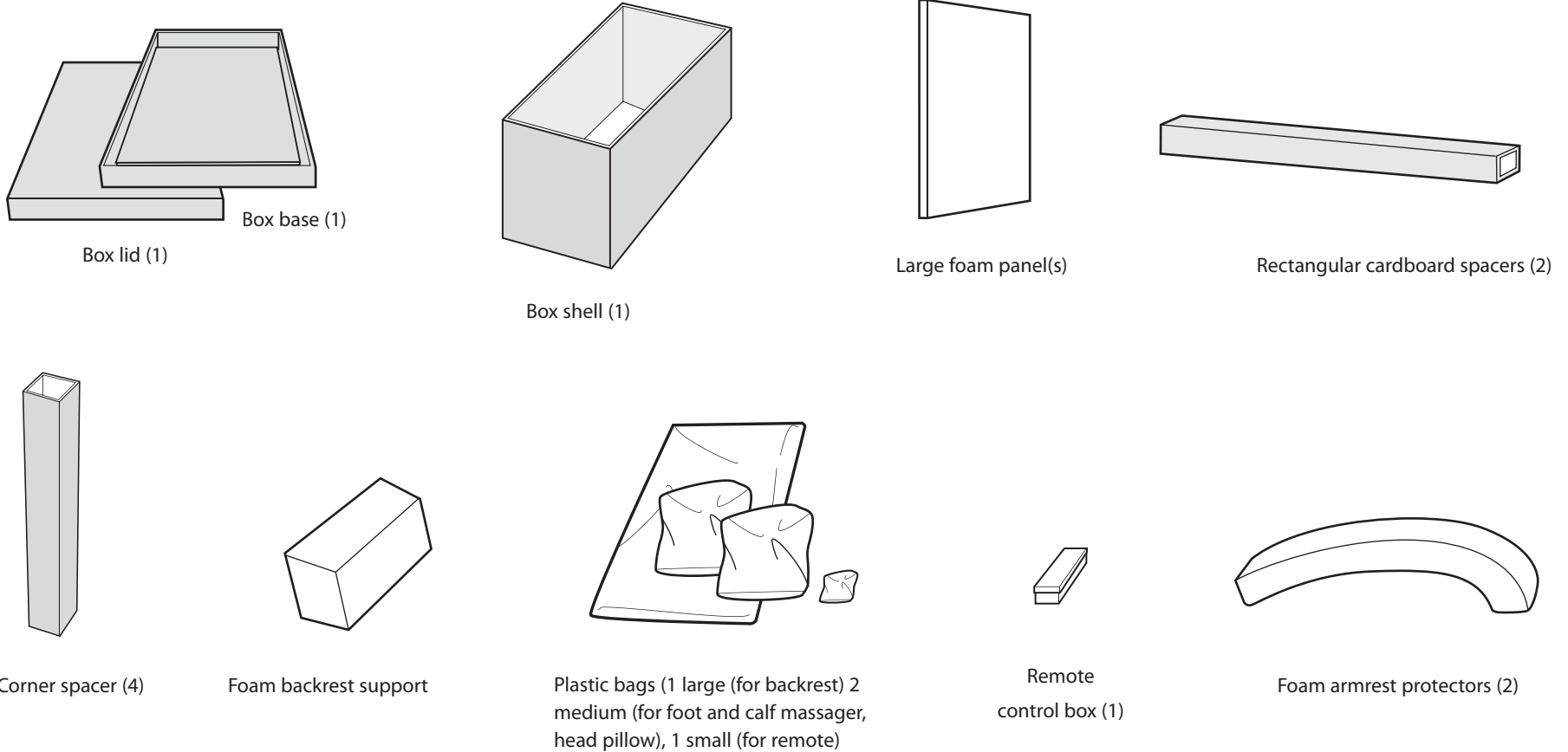

(Fig.1)

UNPACKING THE CHAIR

1. Cut the shipping bands and remove the box lid (Fig.2).
2. Remove the cardboard spacer from on top of the backrest and from the front of the calf+foot massager (Fig.3).
3. Remove the corner spacer from each side of the headrest (Fig.4).
4. Remove the box shell (Fig.5).

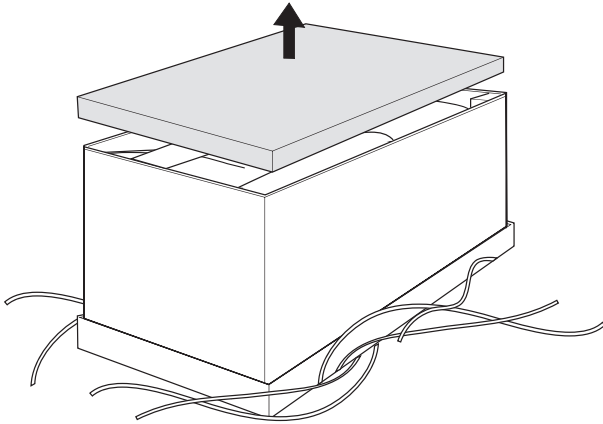

(Fig.2)

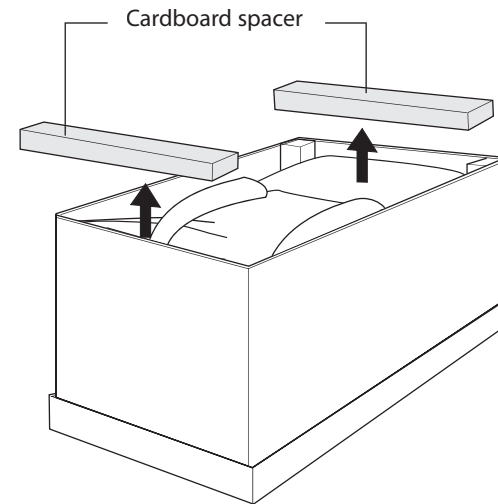

(Fig.3)

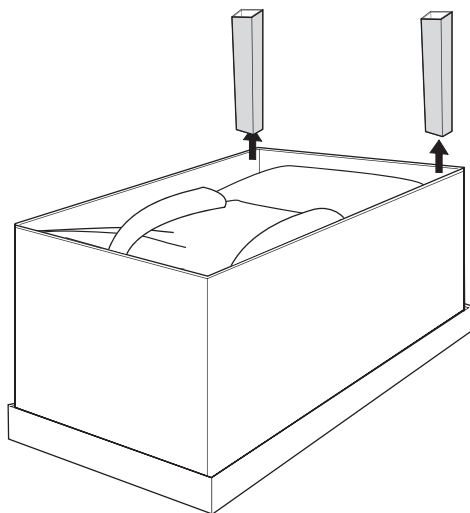

(Fig.4)

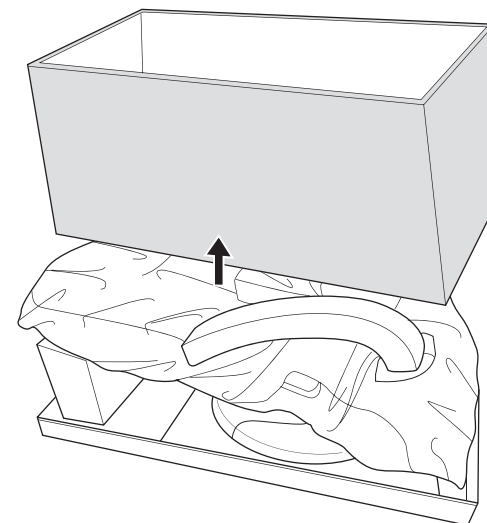

(Fig.5)

5. Remove the foam backrest support from beneath the backrest (Fig.6).
6. Remove the foam armrest protector from each arm (Fig.7).
7. Remove the head pillow from on top of the seat.
8. Remove the protective plastic bags from the backrest and calf+foot massager.
9. Remove the remote control from its box (located on top of the seat).
10. Remove the massage softening pad from on top of the backrest.
11. Using two people, lift the chair from the box base.

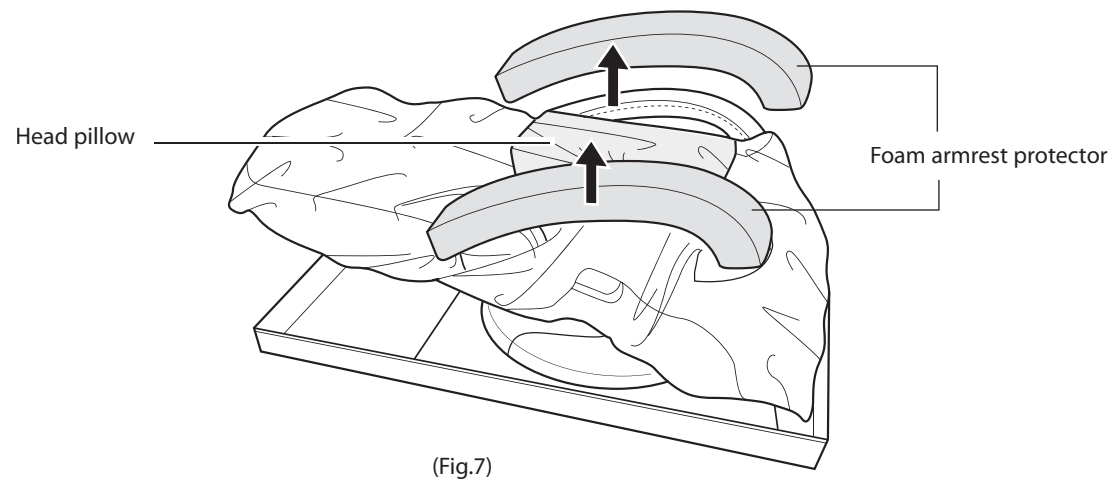
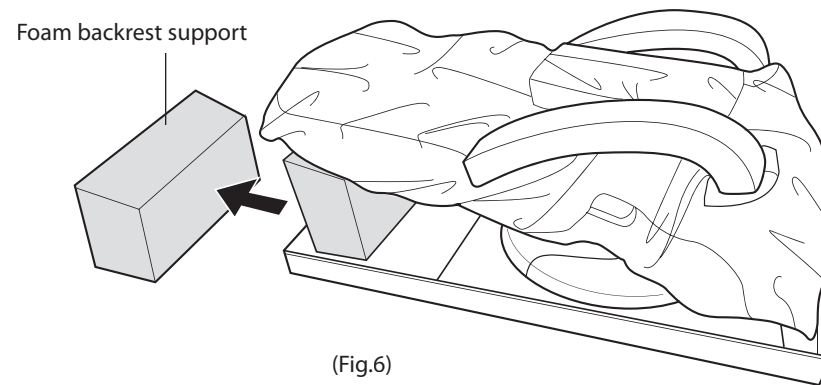

PACKAGING THE CHAIR FOR SHIPPING

1. Use the remote control to fully recline the backrest, then power off and unplug the chair.
2. Detach the head pillow from the chair.
3. Place the large foam panel(s) inside the box base and position the box base such that you have room to move freely on all sides of it.
4. Using two people, lift the chair gently onto the box base.
5. Place the remote control into the small plastic bag, then into the remote control box.
6. Slip the large plastic bag over the backrest and one of the medium plastic bags over the calf+foot massager.
7. Place the head pillow into one of the medium plastic bags, then place it on top of the seat.
8. Place a foam armrest protector on top of each arm and secure it using shipping tape.
9. Place the foam backrest support beneath the headrest.
10. Place the box shell onto the box base.
11. Place a corner spacer on each side of the headrest.
12. Place a cardboard spacer between the calf+foot massager and the box side.
13. Place a cardboard spacer across the backrest.
14. Place the box lid onto the box and secure it using shipping bands.