

REPLACING THE FOOT AND CALF MASSAGER

To ensure that Human Touch® products are repaired in a manner that is fully consistent with the practices used during the manufacturing process, Human Touch requires that all product repairs are performed using only factory-new parts and in accordance with these product repair instructions.

SERVICE LEVEL: 3

Tools Required: Nail clipper or other instrument suitable for cutting zip ties, Phillips-head screwdriver, flat-head screwdriver, vice grip, small hammer.

NOTE: SAVE ALL SCREWS FOR USE DURING REASSEMBLY.

REMOVING THE MASSAGER

1. Locate the connector box on the bottom left side of the chair, near the foot and calf massager (Fig.1).
2. Using a Phillips-head screwdriver, remove the two screws that secure the connector box cover, remove the cover, then disconnect the red connector.
3. Cut any zip ties that secure the cable that runs from the backrest to the foot and calf massager, to free the cable from the chair base.
4. Standing in front of the foot and calf massager, detach the upholstered flap that covers the massager frame (Fig.2).

NOTE: It is helpful to flip the upholstered flap up onto the seat cushion and place an object on top of it to hold it out of the way.

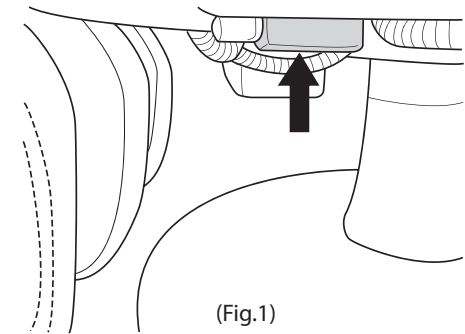

(Fig.1)

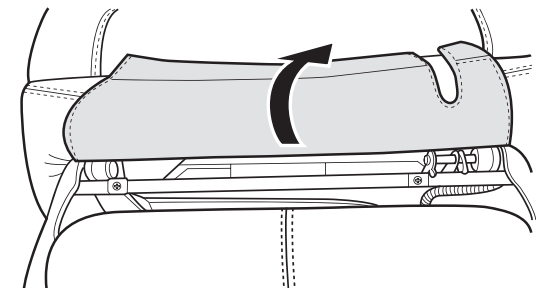

(Fig.2)

5. Using a Phillips-head screwdriver, remove the two screws from the two brackets on the massager frame, then remove the brackets. (Fig.3).
6. Locate Pin A, then use a flat-head screwdriver (and a vice-grip if necessary) to loosen the pin. Do not remove the pin from the bracket.
It is helpful to leave it in place to hold the massager at the correct angle while removing the second pin.
7. Locate Pin B, use a flat-head screwdriver to loosen the pin, then use a vice-grip to remove the pin from its bracket.
8. Use your hand or the vice-grip to remove Pin A from its bracket.
9. Remove the massager from the chair (Fig.4).

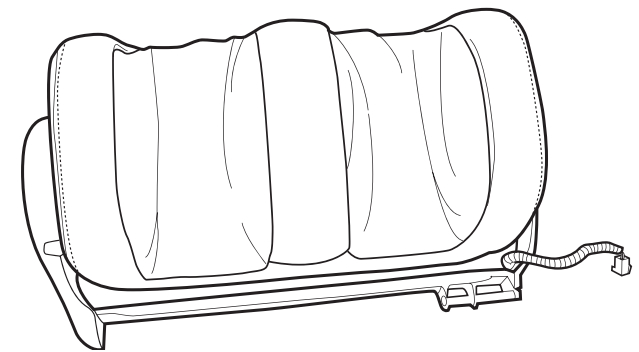
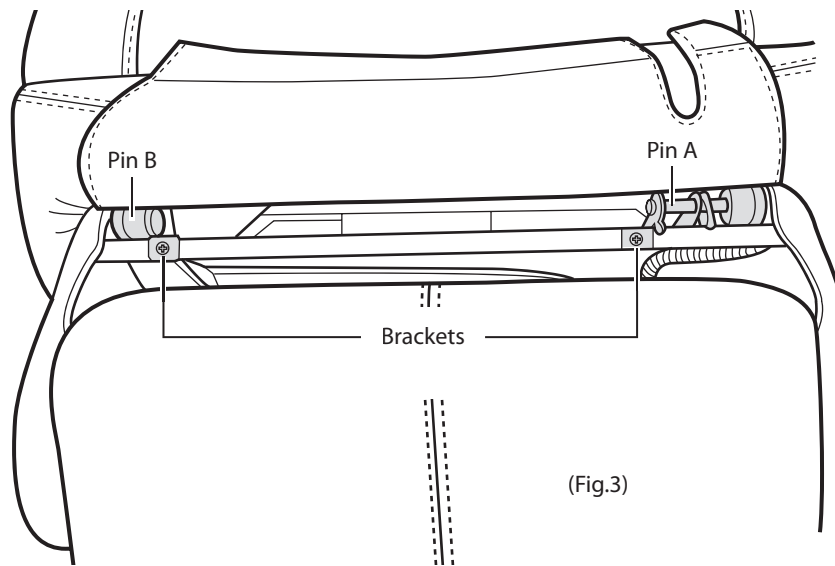

INSTALLING THE NEW MASSAGER

1. Place the new massager into position, then insert pin A just far enough into the left side of bracket A to hold it in place.
2. Line up the actuator bracket with the mounting point on Bracket A, then push the pin through the bracket as far as it will go by hand.
3. Line up the left side of the massager with Bracket B, then insert Pin B through the bracket as far as it will go by hand.
4. Use a small hammer to push both pins until the pin heads are flush with the bracket.
5. Using a Phillips-head screwdriver, replace the two brackets on the front of the massager frame and secure them using the screws you removed earlier.
6. Reinstall the upholstered flap, by wrapping it around the massager frame and securing it using the hook and loop fasteners.
7. Reconnect the red connectors on the lower left-hand side of the backrest.
8. Replace the connector box cover and secure it, using a Phillips-head screwdriver and the two screws you removed earlier.
9. Install new zip ties to replace those you removed earlier, to secure the massager cabling to the chair base, out of sight.

