



REPLACING THE BACKREST

To ensure that Human Touch® products are repaired in a manner that is fully consistent with the practices used during the manufacturing process, Human Touch requires that all product repairs are performed using only factory-new parts and in accordance with these product repair instructions.

SERVICE LEVEL: 3

Tools Required: Pliers, vice grip, Phillips-head screwdriver, small hammer, nail clipper or other instrument suitable for cutting zip ties, new zip ties, 5 mm Allen wrench

NOTE: This procedure can be completed by one person, although having a second person is helpful when installing the new backrest. SAVE ALL PARTS FOR USE DURING REASSEMBLY.

GET READY

1. Remove the head pillow and backrest pad (see Use & Care manual for more information).
2. Push down on the backrest release lever, then fold the backrest forward onto the chair seat (Fig.1).
3. Power off the chair and unplug it.

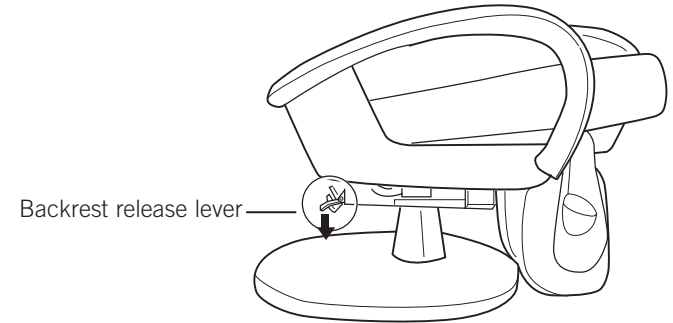

(Fig.1)

REMOVING THE BACKREST

1. Locate the connector box on the bottom left-hand of the chair, use a small phillips-head screw driver to pop open the connector box cover, remove the cover, then disconnect the two connectors (Fig.2).
2. Locate the connector box on the bottom right-hand side of the chair, use a Phillips-head screwdriver to remove the two screws that secure the connector box cover, remove the cover, then disconnect the connector (Fig.3).
3. Using a nail clippers, or other suitable instrument, cut and remove all zip ties that secure the two backrest connectors and cables to the bottom of the chair, being careful not to cut the wire casing.

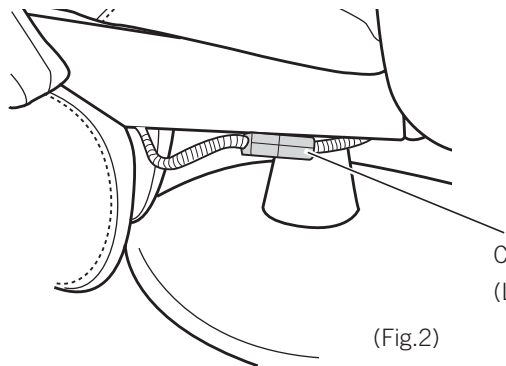

Connector box
(Left-hand side of the chair)

(Fig.2)

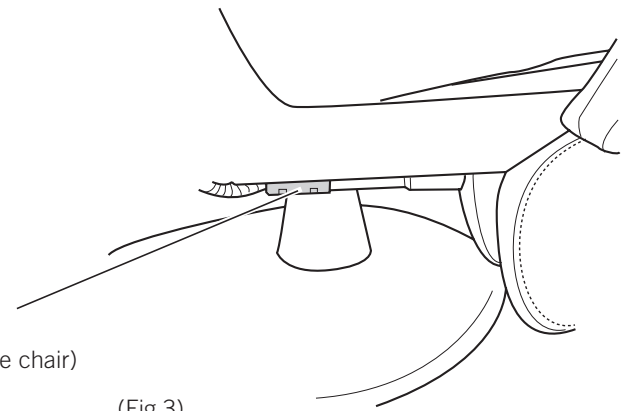

Connector box
(Right-hand of the chair)

(Fig.3)

4. Using a 5-mm Allen key, remove the two inside screws that secure the bottom of the side panel to the chair frame (Fig.4).
5. Using a Phillips-head screwdriver, remove the inside screw that secures the top of the side panel to the chair frame (Fig.5).
6. Pull gently outward on the bottom of one of the side panels to remove it (Fig.4 & 5).
7. Use a needle-nosed pliers to remove the cotter pin from the side panel, then use a vice grip to pry the hinge pin loose from the side panel and remove it (Fig.6).

NOTE: When the hinge pin is removed, the two spacers that are located between the backrest and the chair base will most likely fall off (Fig.7). Be sure to set these spacers aside for use during reassembly.
8. Repeat steps 4 and 5 on the other side panel.
9. Carefully lift the backrest up and off the chair base.

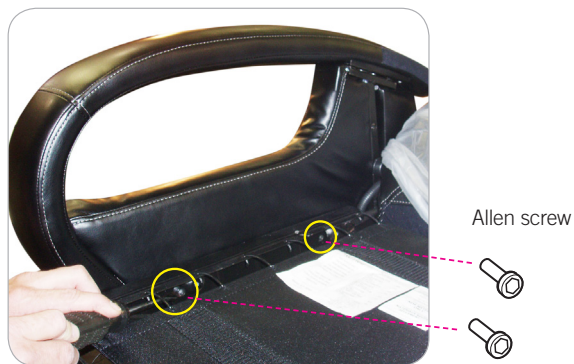

(Fig.4)

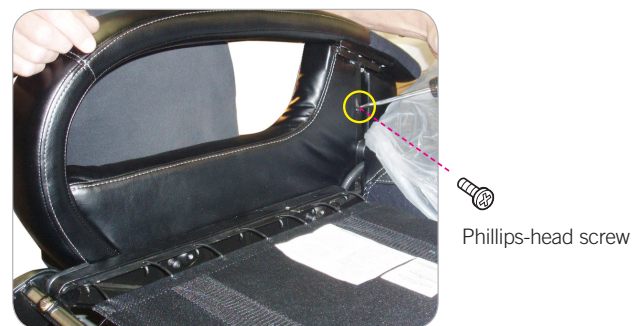

(Fig.5)

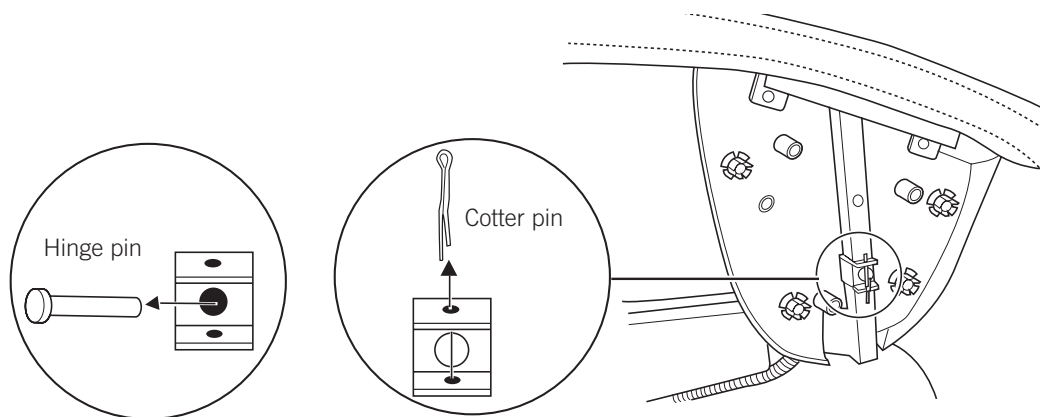

(Fig.6)

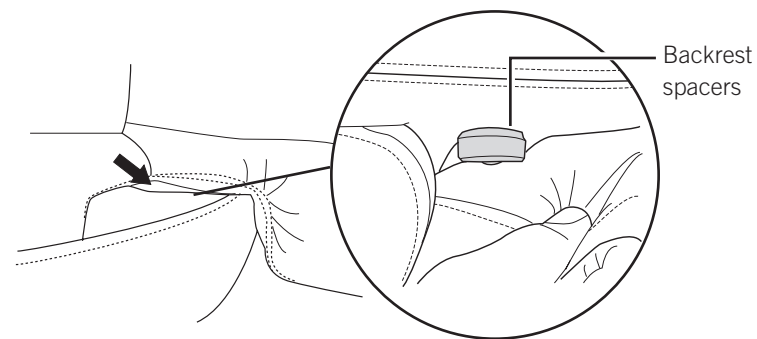

(Fig.7)

INSTALLING THE NEW BACKREST

1. Place the new backrest into position, face-down on the chair base.
2. From the outside of one of the side panels, insert the hinge pin through the hole, just until it is visible on the inside of the side panel.
3. Place the two spacers into position on the inside of the side panel, with the smaller spacer between the larger spacer and the side panel, then push the hinge pin through both spacers (Fig.8).
4. Use your fingers to line up the bracket in the side of the backrest and the hinge pin; you will need to pull up slightly on the lower part of the backrest to properly align the hinge pin with the bracket. (NOTE: Use your fingers to locate the circular bracket in the side of the backrest before attempting to insert the hinge pin into the backrest. You can easily locate the hole by pushing firmly inward on the side of the backrest until you feel the metal bracket beneath the upholstery.)
5. Insert the hinge pin as far into the bracket as possible, then use a small hammer to install it completely into the bracket.
6. Insert the cotter pin into the hinge pin, then use a needle-nosed pliers to bend the ends back.
7. Replace the side panel.
 - a. Using a 5-mm Allen key, replace the two inside screws that secure the bottom of the side panel to the chair frame (Fig.9).
 - b. Using a Phillips-head screwdriver, replace the inside screw that secures the top of the side panel to the chair frame (Fig.10).

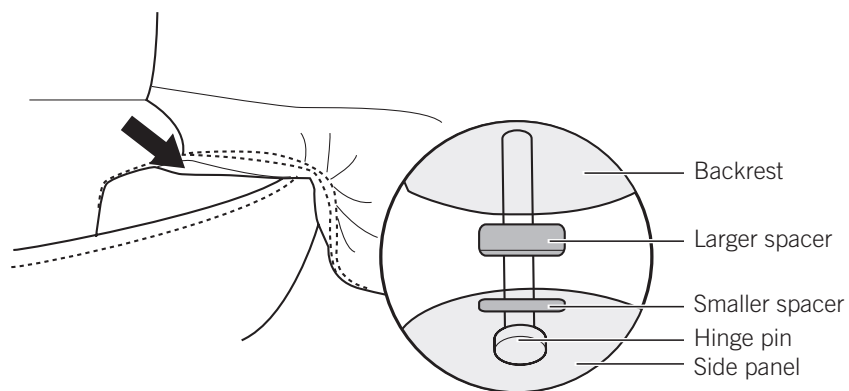

(Fig.8)

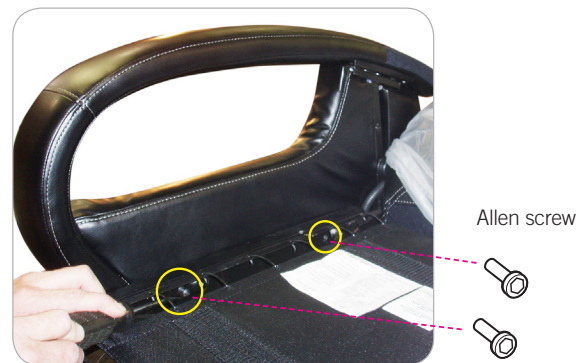

(Fig.9)



(Fig.10)

8. Repeat steps 2 - 7 on the other side panel.
9. Reconnect the cables at the connector box on the bottom right-hand side of the chair (Fig.11).
10. Using a Phillips-head screwdriver, secure the connector box cover using the two screws you removed earlier.
11. Reconnect the cables at the connector box on the bottom left-hand side of the chair (Fig.12).
12. Using Phillips-head screw driver, secure the connector box cover using the two screws you removed earlier.
13. Replace the zip ties you removed previously, to secure the connector boxes and cables to the bottom of the chair.
14. Reinstall the chair pads (See the Use & Care manual for instructions).
15. Plug in and power on the chair, then verify that both the massage and recline functions work.

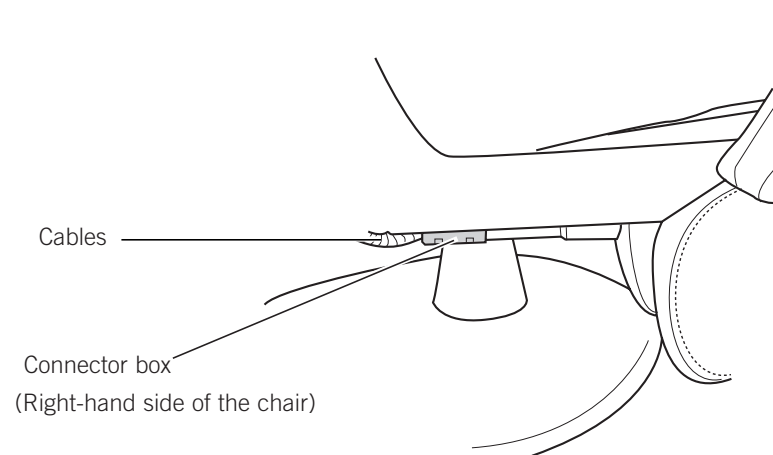

(Fig.11)

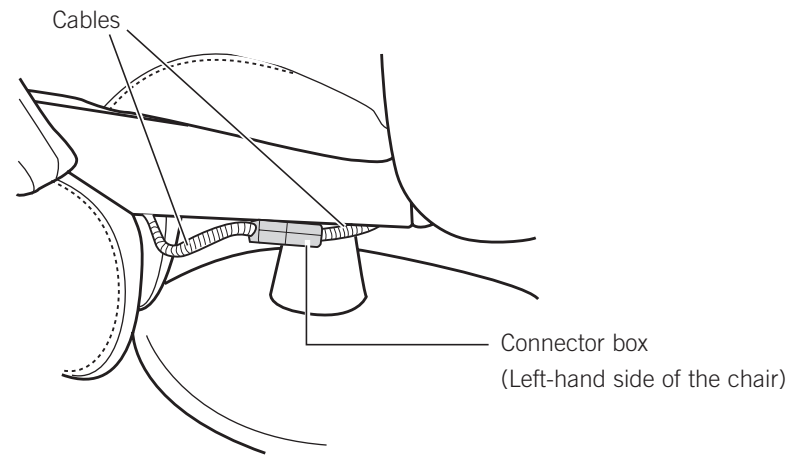

(Fig.12)