

REPLACING AN ARMREST

To ensure that Human Touch® products are repaired in a manner that is fully consistent with the practices used during the manufacturing process, Human Touch requires that all product repairs are performed using only factory-new parts and in accordance with these product repair instructions.

SERVICE LEVEL: 2

Tools Required: 16-mm wrench, 2 people (to turn chair on its side)

NOTE: SAVE ALL SCREWS FOR USE DURING REASSEMBLY.

GET READY

1. Press down on the electronic footrest lever on the right-hand side of the chair to fully retract the foot and calf massager.
2. Power off the chair and unplug it.
3. Using two people, turn the chair gently on its side, with the armrest you wish to replace on top (Fig.1).

REMOVING AN ARMREST

1. On the bottom of the chair near the front, locate the nut that secures the armrest to the chair frame, then loosen the nut as far as possible using a 16-mm wrench (Fig.2).
2. Pull up on the armrest to provide further access to the nut, then remove the nut.
3. Push the armrest toward the front of the chair until it disengages from the slot that secures it, then remove it from the chair base (Fig.3).

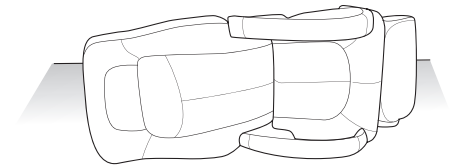

(Fig.1)

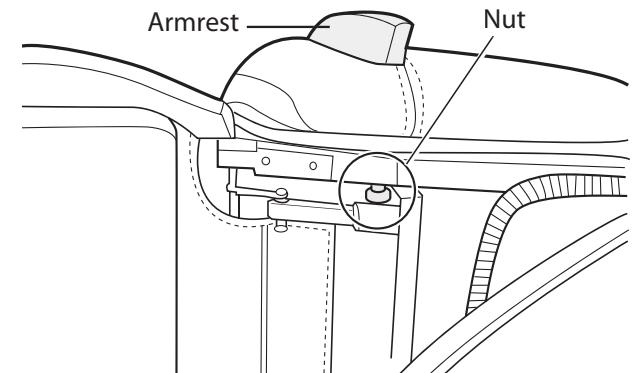

(Fig.2)

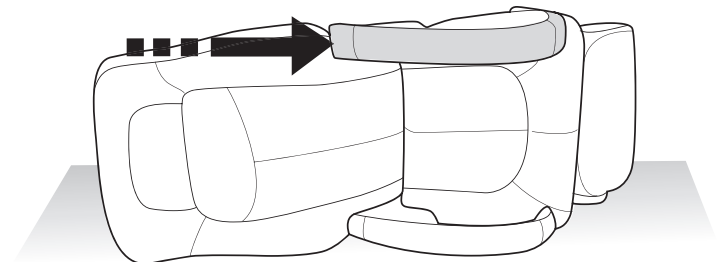

(Fig.3)

INSTALLING THE NEW ARMREST

1. From the front of the chair, slide the new armrest into place. The tab on the bottom of the armrest installs into a slot on the chair arm to secure it (Fig.4).
2. Using a 16-mm wrench, replace the nut that secures the armrest to the chair base.

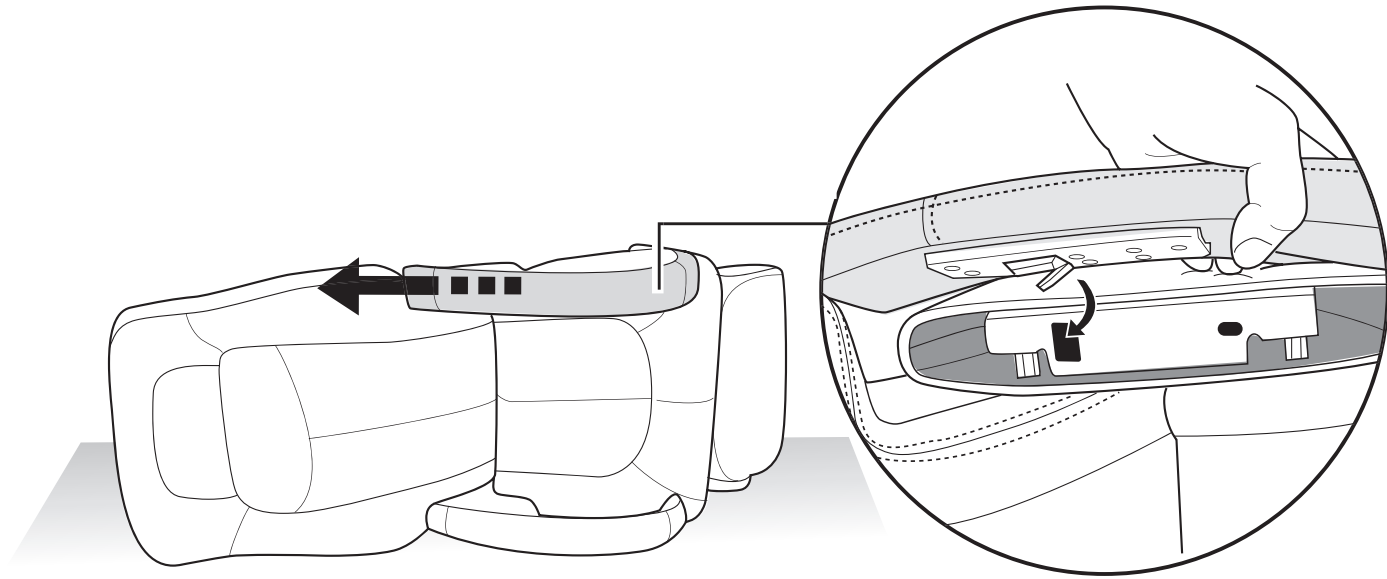

(Fig.4)