

## 2. Install the side panels.

- Align the four side panel holes with the corresponding mounting holes on the armrest, then push the side panel firmly into place (Fig.A).
- Using a flat-head screwdriver, pry the top of one of the fasteners up off of the fastener base and hold it in that position (Fig.B).
- Using your other hand, locate one of the four side panel mounting holes on the inside of the armrest (Fig.C).
- Push the base of the fastener firmly and completely into the hole, then push the top of the fastener firmly inward to lock it.
- Repeat steps (b) and (c) to install the other three fasteners. **NOTE:** Access the upper rear mounting hole from the inside of the arm, near the seat cushion. To install the upper front fastener, you may want to rotate the foot and calf massager for easier access.
- Repeat steps (a) to (e) to install the other side panel.

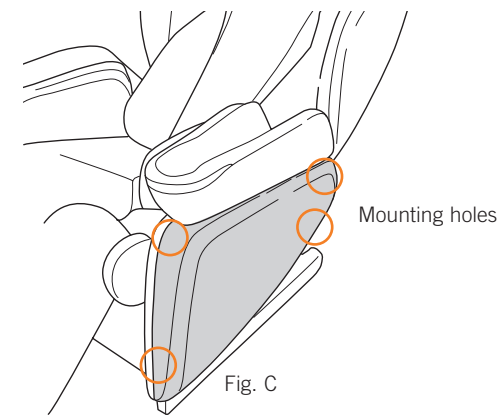
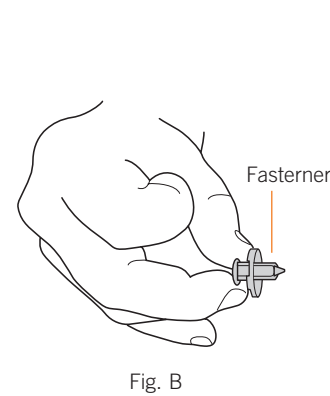
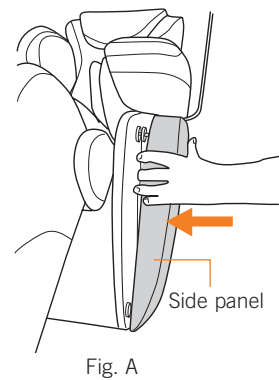

## 3. Install the power cord and power on the chair.

- Plug the power cord into the power jack on the back of the chair.
- Plug the other end of the power cord into a grounded 120V outlet.
- Turn the power switch on the back of the unit to On (I).

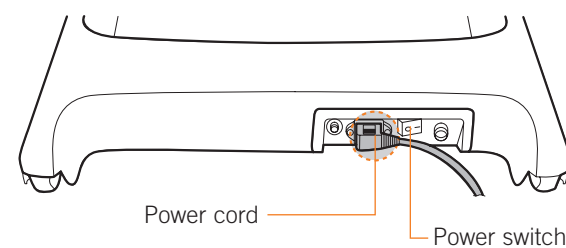

## 4. Press the Power button on the remote control to power it on.

When you have ensured that the area around the chair is free from children and pets (and will remain that way for the duration of the chair's use), select CONTINUE.



# HT-Navitas Sleep

## DELIVERY AND ASSEMBLY GUIDE

### Unpack the box

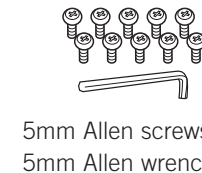
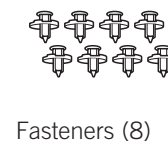
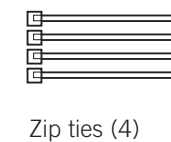
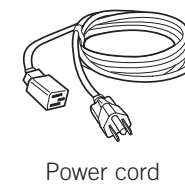
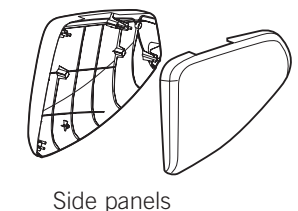
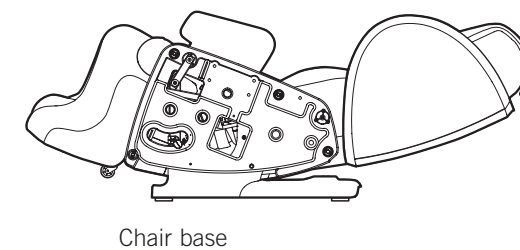

### Extra (in case needed)

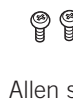
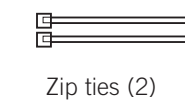

## CHOOSE A LOCATION

When deciding where to place your HT-Navitas, consider the following:

- Place the unit on a flat surface, away from direct sunlight or any other direct heat source (to avoid fading).
- If you wish to place the unit on a hard surface, it is recommended that you place a piece of carpet or a soft mat underneath it to avoid damaging the floor (minimum 48" x 28").
- To accommodate the footrest when deployed, make sure the area in front of the chair is clear for at least 32".

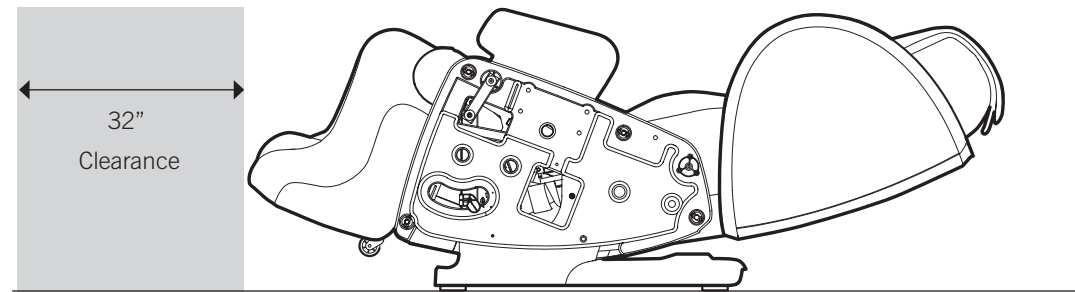

## ASSEMBLE THE CHAIR

### 1. Install the armrests.

- Align the four holes on the armrest mounting bracket with the corresponding holes on the chair frame.  
**IMPORTANT:** Orient the armrest with the open end facing backward, as shown.
- Using a 5mm Allen wrench (provided), install one Allen screw with flat-washer into each of the four mounting holes to secure the armrest to the chair.

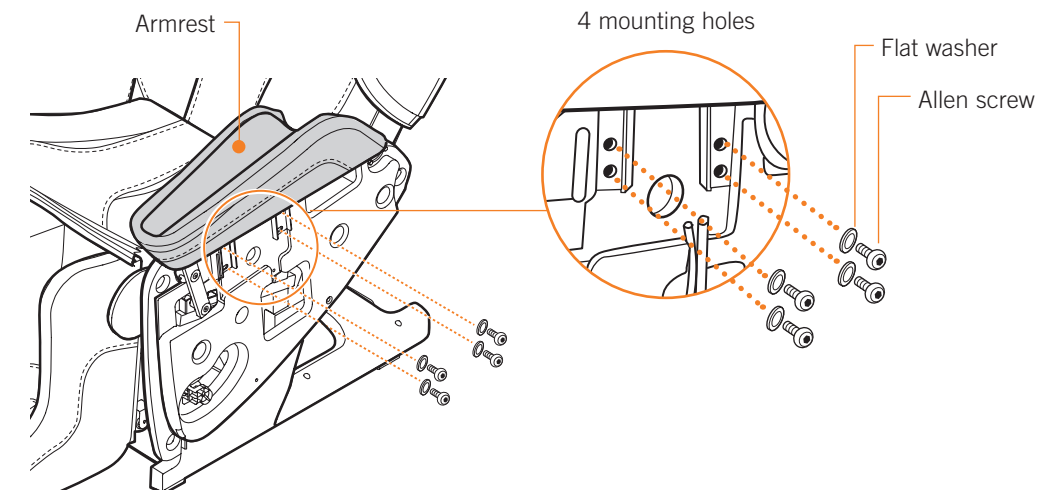

- Connect the air two air tubes on the armrest to the corresponding air tubes on the chair (yellow/yellow, black/black), then secure each connection tightly using a provided zip-tie.
- Repeat steps 1 – 3 to install the other armrest.

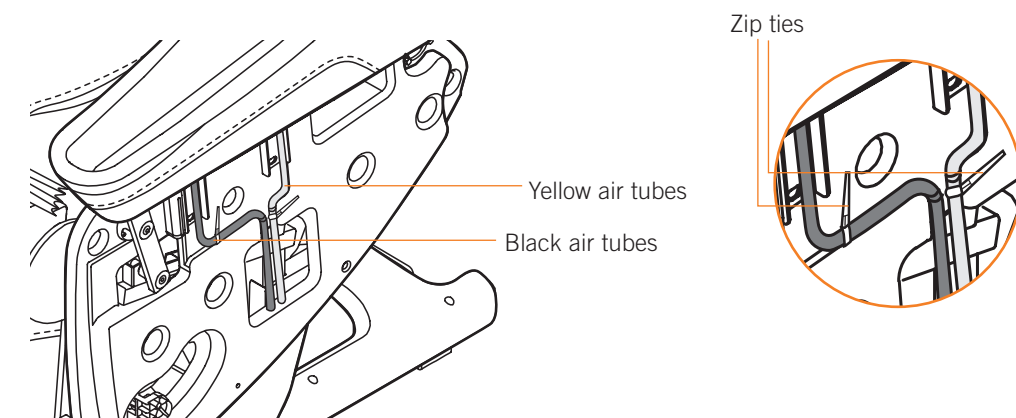

## MOVE THE CHAIR TO THE DESIRED LOCATION

**CAUTION:** Use two or more people to lift the chair out of the box or move it, to avoid injury or damage to the chair. Do not move the chair with anyone seated in it. Do not hold the seat, front of the footrest, or shoulder unit when moving the chair. Make sure the power cord is secured out of the way before moving the chair.

### To move the chair:

- Carefully push down on the upper part of the backrest to tilt the chair backward, balancing the chair weight carefully to avoid dropping it.
- Roll the chair on its casters to the desired location.
- Gently lower the chair all the way to the floor. **WARNING:** Dropping the front of the chair to the floor may damage the chair and/or floor.

