

# REPLACING THE FOOT AND CALF MASSAGER

To ensure that Human Touch® products are repaired in a manner that is fully consistent with the practices used during the manufacturing process, Human Touch requires that all product repairs are performed using only factory-new parts and in accordance with these product repair instructions.

SERVICE LEVEL: 3

Tools Required: Phillips-head screwdriver, flat-head screwdriver, vice grip, small hammer, pliers, nail clipper or other instrument suitable for cutting zip ties, new zip ties

NOTE: SAVE ALL REMOVED PARTS FOR USE DURING REASSEMBLY

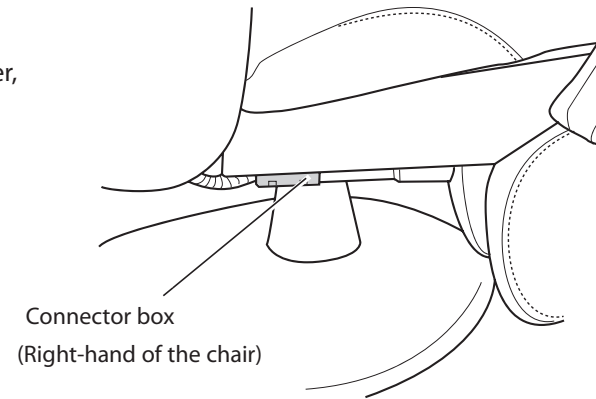

(Fig.1)

## REMOVING THE MASSAGER

1. Power off the chair and unplug it.



2. Locate the connector box on the bottom right-hand side of the chair (Fig.1).
3. Use a Phillips-head screwdriver to remove the two screws that secure the connector box cover, remove the cover, then disconnect the smaller of the two connectors.
4. Using a nail clipper, or other suitable instrument, cut any zip ties that secure the cable that runs from the backrest to the foot and calf massager, to free the cable from the chair base. NOTE: Be careful not to cut the wire casing.
5. Standing in front of the foot and calf massager, detach the upholstered flap that covers the massager frame, then detach the seat pad from the chair base (Fig.2).

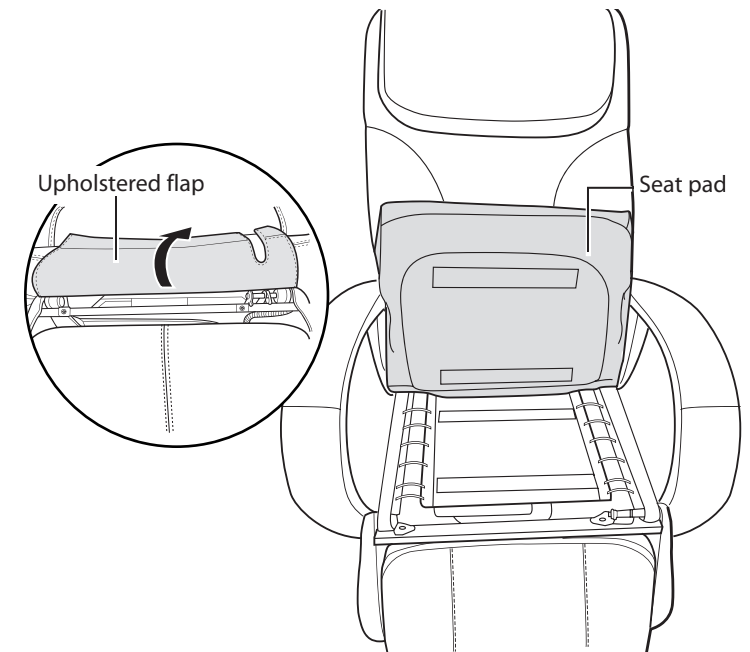

(Fig.2)

6. Locate the two brackets on the top of the foot and calf massager frame (Fig.3). Using a vice-grip, turn each bracket screw counter-clockwise just enough to break the torque (approximately 1/4 turn).
7. Using a Phillips-head screwdriver, remove both screws and their washers from the brackets, then remove the brackets.
8. Locate Pin A, then use a flat-head screwdriver to loosen the pin, by inserting the screwdriver between the pin head and the bracket then using the screwdriver as leverage to push the pin head away from the bracket (Fig.4).

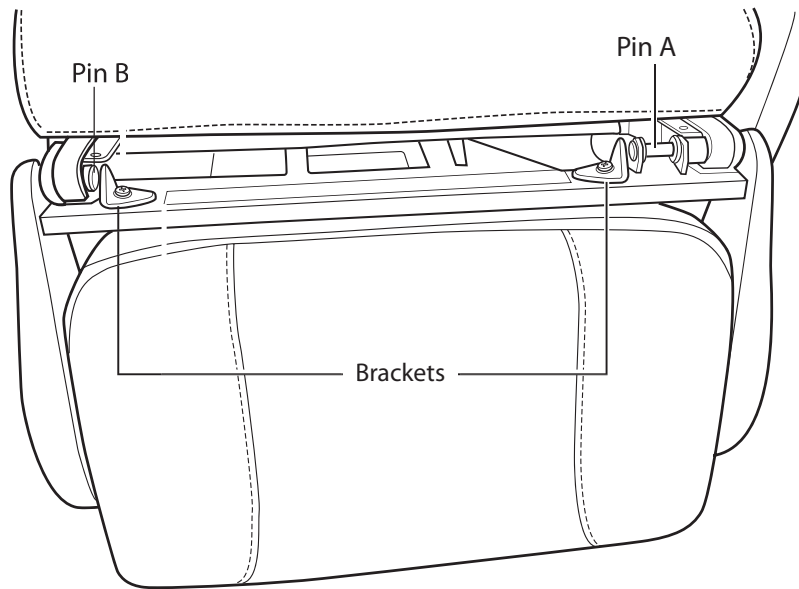

(Fig.3)

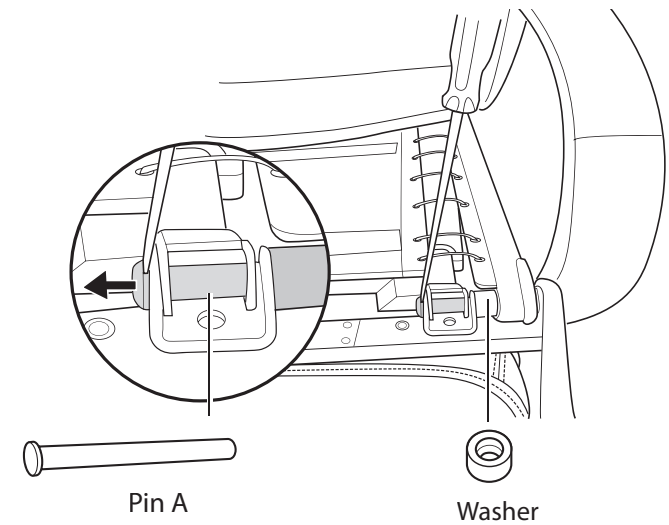

(Fig.4)

9. Using a pliers, remove Pin A from the bracket (Fig.5). As the pin is removed, a washer installed on the right-hand end of the pin will fall to the floor. Be sure to save this washer for use during reassembly.
10. Repeat steps 8 and 9 to remove Pin B from its bracket.
11. Using a nail clipper or other suitable instrument, cut and remove any remaining zip ties that secure the foot and calf massager cabling to the chair.
12. Remove the massager from the chair (Fig.6).

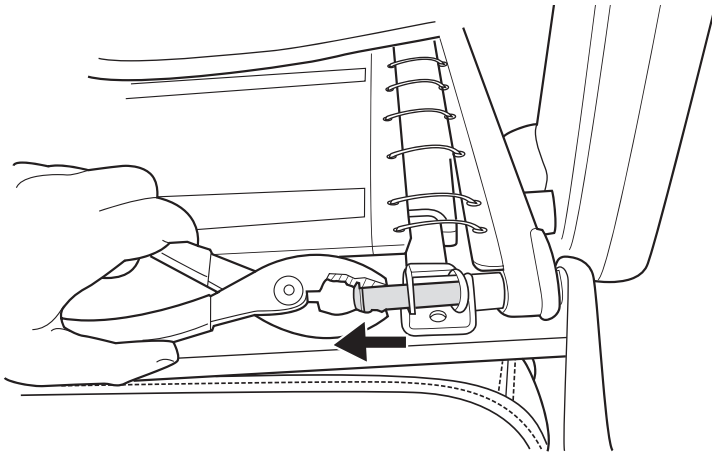

(Fig.5)

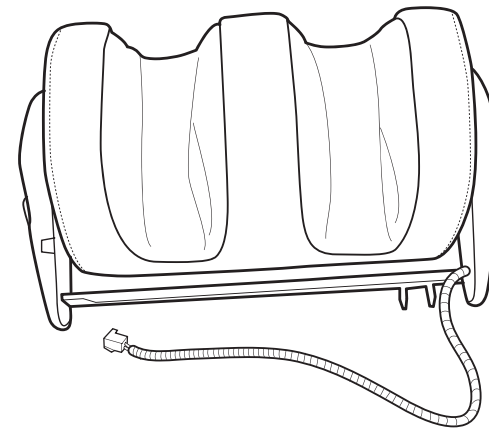

Massager

(Fig.6)

## INSTALLING THE NEW MASSAGER

1. Place the new massager into position, lining up the actuator bracket with the mounting point on the foot and calf massager, then insert pin A just far enough into the left side of bracket A to hold it in place (Fig.7). NOTE: Be sure the rubber spacers remain in place on each side of the chair frame, between the chair frame and the foot and calf massager.
2. Insert the washer onto the right-hand side of Pin A, then push the pin through the bracket as far as it will go by hand (Fig.8).
3. Line up the mounting point on the left side of the massager with Bracket B, then insert Pin B completely into the bracket (Fig.9).
4. Use a small hammer to completely install Pin A and Pin B until both pins are flush with the bracket.
5. Using a Phillips-head screwdriver, replace the two brackets on the front of the massager frame and secure them using the screws and washers you removed earlier (Fig.9).
6. Reinstall the upholstered flap, by wrapping it around the massager frame and securing it using the hook and loop fasteners.
7. Reconnect the connector on the bottom right-hand side of the chair.
8. Replace the connector box cover and secure it, using a Phillips-head screwdriver and the two screws you removed earlier.
9. Install new zip ties to replace those you removed earlier, to secure the massager cabling to the chair base, out of sight.

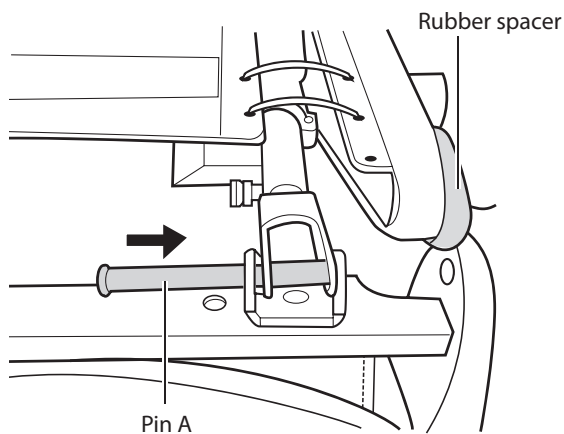

(Fig.7)

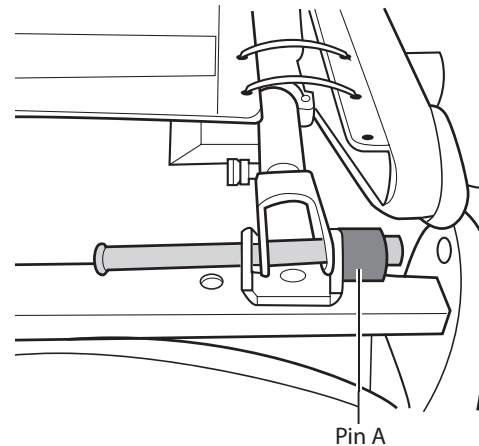

(Fig.8)

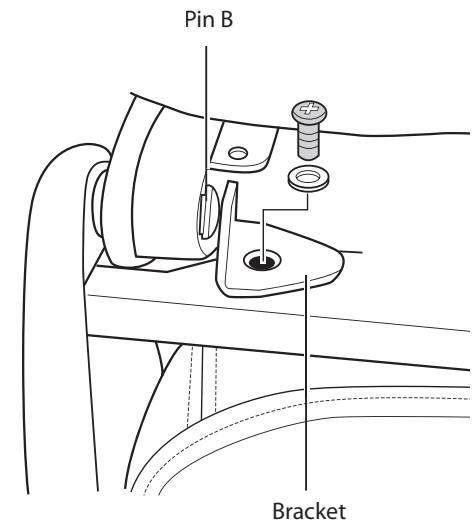

(Fig.9)