



REPLACING AN ARMREST

To ensure that Human Touch® products are repaired in a manner that is fully consistent with the practices used during the manufacturing process, Human Touch requires that all product repairs are performed using only factory-new parts and in accordance with these product repair instructions.

SERVICE LEVEL: 2

Tools Required: 3/6-inch Allen Key. **NOTE:** SAVE ALL SCREWS FOR USE DURING REASSEMBLY.

REPLACING AN ARMREST

1. Use the remote to fully deploy the foot and calf massager to a horizontal position (Fig.1).
2. Pull up on the seat pad to remove it from the chair.
3. Using a 3/16-inch Allen Key, remove the two screws/washers that secure the armrest to the chair (Fig.2).
4. Pull the armrest straight up until the mounting posts on the lower inside edge of the armrest clear the mounting post guides, then remove the armrest from the chair (Fig.3).

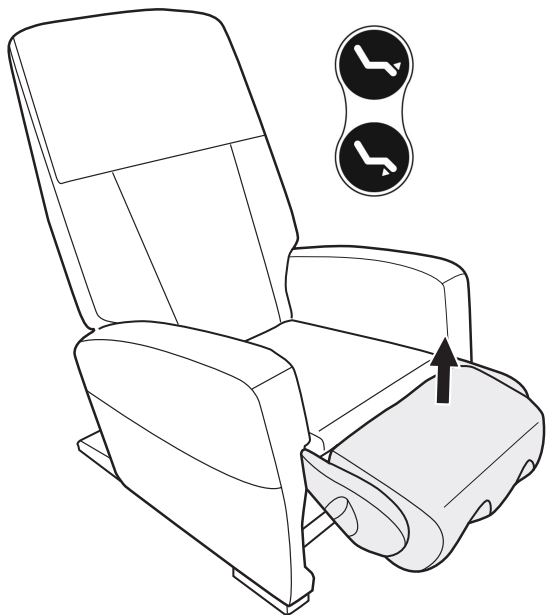
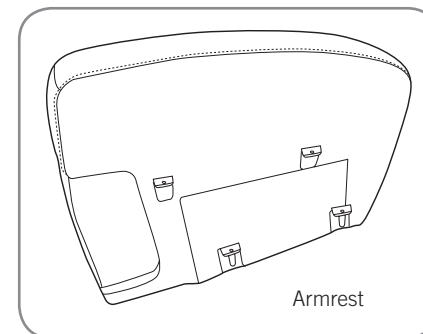

(Fig.1)

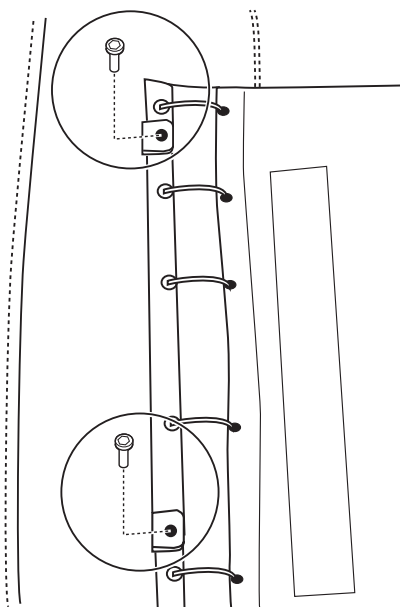

(Fig.2)

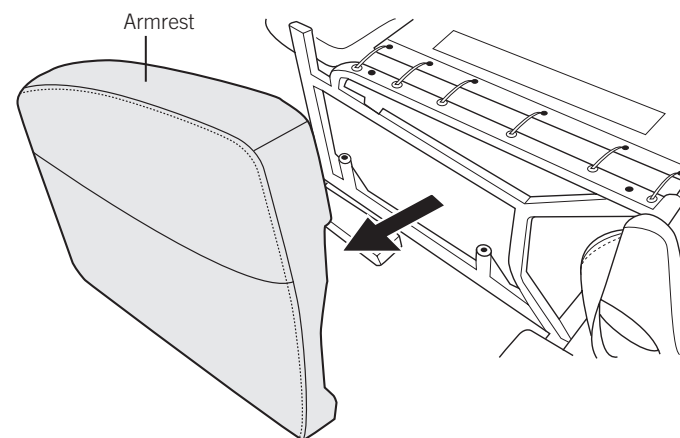

(Fig.3)

INSTALLING THE NEW ARMREST

1. Insert the two mounting posts on the lower inside edge of the armrests into the two corresponding mounting post guides (Fig.4).
2. Lower the armrest into position, until the mounting brackets on the armrest meet the screw holes on the chair frame (Fig.4).
3. Replace the two screws/washers to secure the armrest to the chair (Fig.4).
4. Align the hook and loop fasteners on the bottom of the seat pad with those on the seat canvas, then press the seat pad into place to secure it.
5. Use the remote to retract the foot and calf massager.

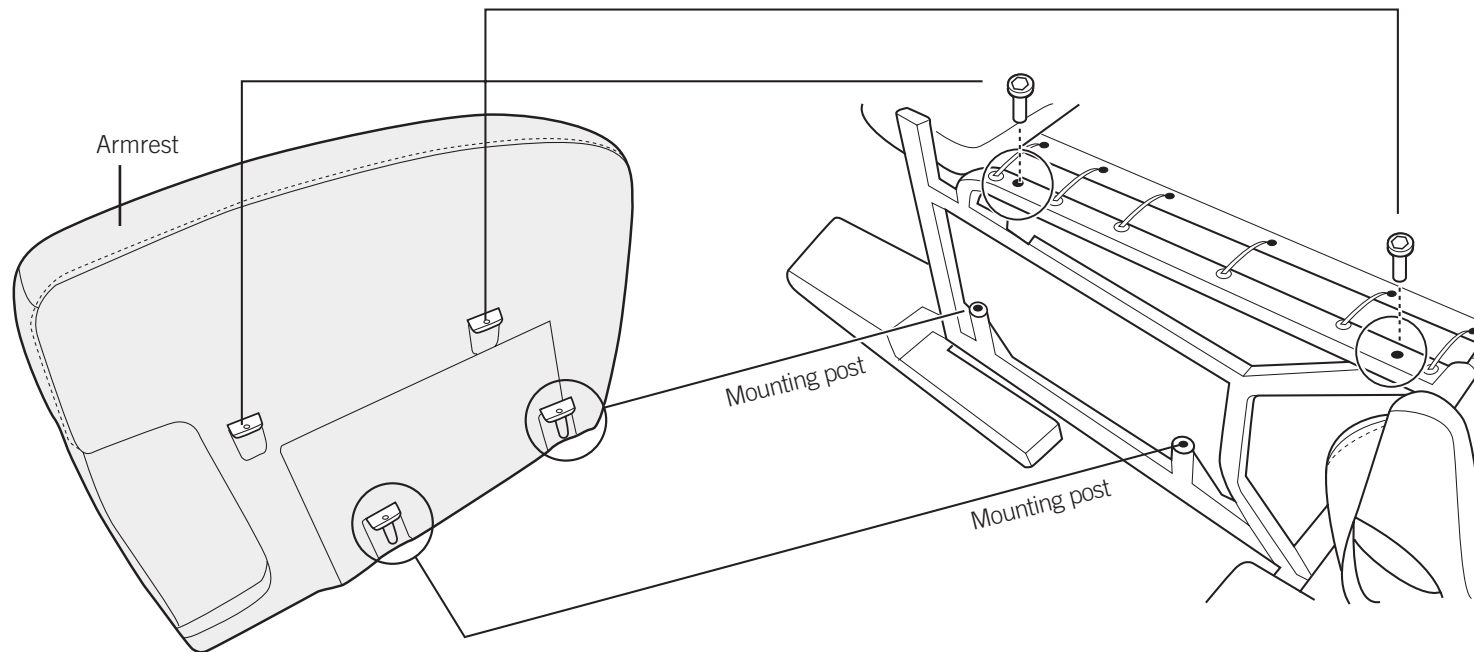

(Fig.4)