

REMOVING THE SEAT PAD

To ensure that Human Touch[®] products are repaired in a manner that is fully consistent with the practices used during the manufacturing process, Human Touch requires that all product repairs are performed using only factory-new parts and in accordance with these product repair instructions.

SERVICE LEVEL: 2

Tools Required: NONE.

REMOVING THE SEAT PAD

1. Remove the two screw knobs from the bottom of the backrest (Fig. 1).
2. Use the remote control to fully recline the chair.
3. Power off the chair and unplug it.
4. Disconnect all cables that connect the backrest to the left-hand side of the chair base (Fig.2).
5. Lift backrest off the chair base.

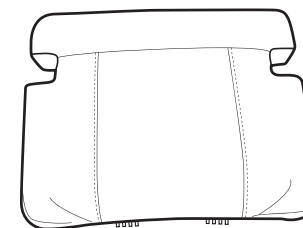

Seat pad

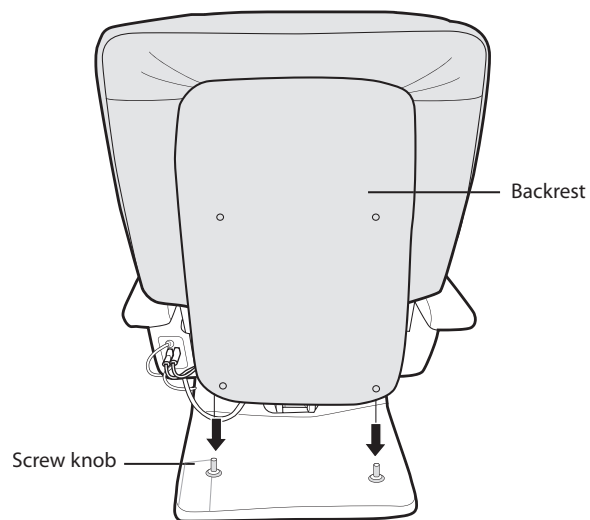

(Fig.1)

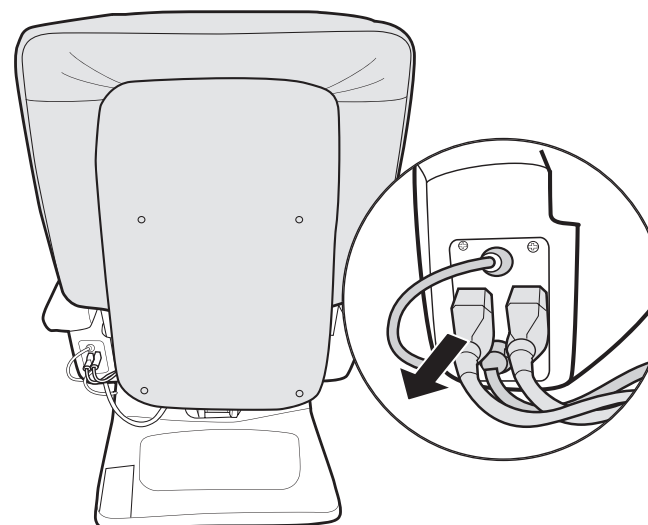

(Fig.2)

6. Facing the rear of the chair, pull up on the back of the seat pad to expose the seat air tubing (Fig.3).
7. Using your fingers, slide the zip tie on each tube upward approximately one inch, to loosen the tube connection to the fitting (Fig.4).
8. Standing facing the front of the chair, grasp both sides of the seat pad. Pull upward and toward you to release the seat pad from the chair base (Fig.5).
9. Lift one side of the seat pad upward until it clears the armrest, then pull the seat pad up and off the chair base (Fig.6).

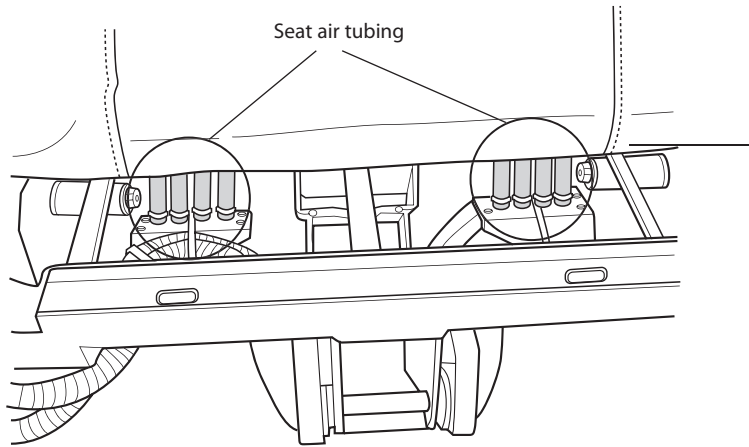

(Fig.3)

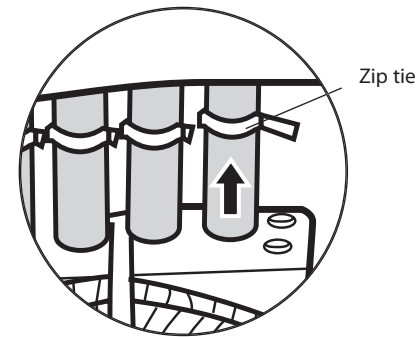

(Fig.4)

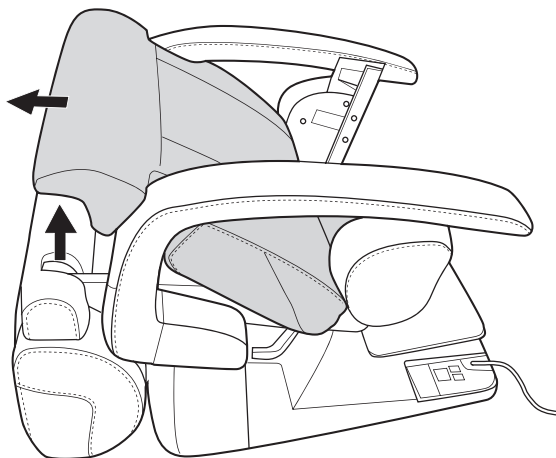

(Fig.5)

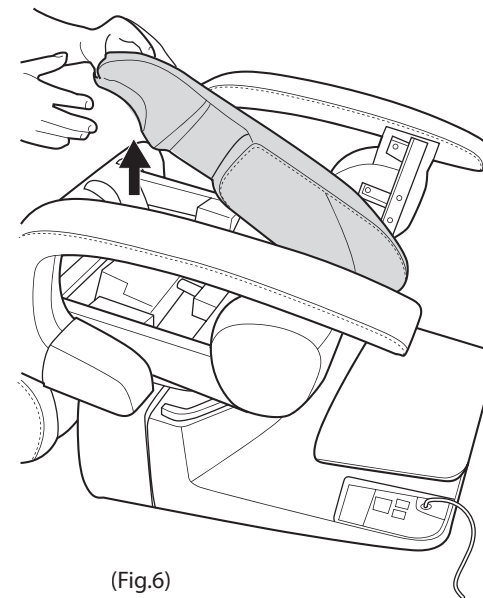

(Fig.6)

INSTALLING THE NEW SEAT PAD

1. Locate the two seat pad sockets on the chair base (Fig.7).
2. Place the seat pad into position, aligning the two tubing groups on the bottom of the seat pad with the sockets on the chair base (Fig.7).
3. Aligning the tubing with the corresponding fitting, push the seat pad downward as far as it will go.
4. Using your fingers, slide the zip tie on each tube down to the end of the tube, to secure the tube to the fitting.
5. Slide the backrest onto the chair base.
6. Plug in the chair and power it on, then use the remote control to raise the backrest to an upright position.
7. Replace the two screw knobs to secure the backrest to the chair base.
8. Use the remote control to verify that the seat massage is now working properly.

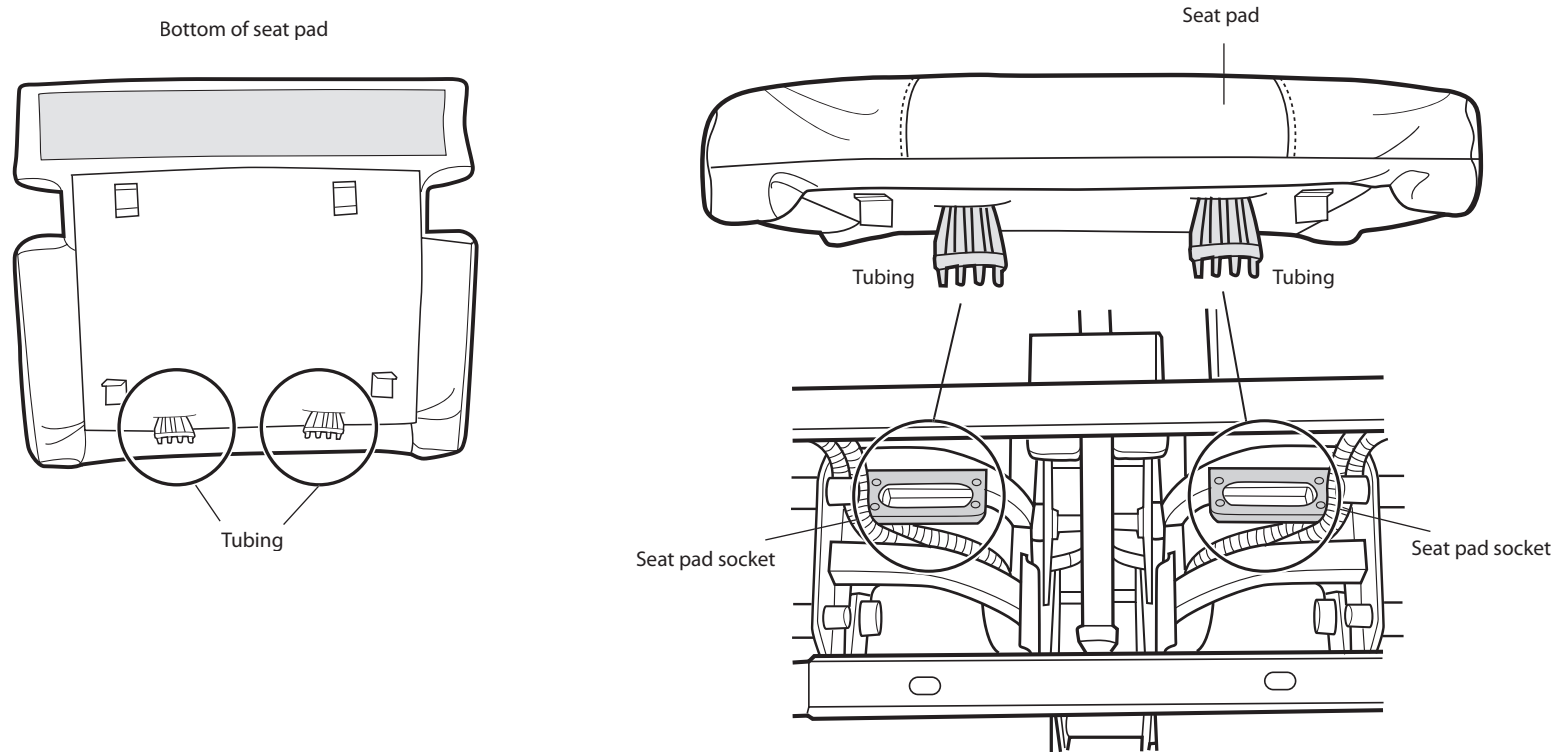

(Fig.7)